

LECTURE NOTE ON MANUFACTURING TECHNOLOGY



4TH SEMESTER

**PREPARED BY
MICHAEL SUVEER
GUEST FACULTY
DEPARTMENT OF MECHANICAL ENGG**



GOVERNMENT POLYTECHNIC, NUAPADA

Government of Odisha

ସରକାରୀ ବହୁବୃତ୍ତି ଅନୁଷ୍ଠାନ, ନୂଆପଡ଼ା

TOOL MATERIAL

Manufacturing technology:

It is defined as a field of study focused on process techniques or equipments, cost reduction, increased efficiency, enhanced reliability, security safety and anti-pollution measures are its objects.

Characteristics of the ideal cutting tool material:

- a. Hot hardness- material must remain harder than work material at elevated operating temperatures.
- b. Wear resistance-material must withstand excessive wear even though the relative hardness of the tool work material changes.
- c. Toughness-it actually implies a combination of strength and ductility. It is the resistance of the material to the shock and vibrations.
- d. Frictional coefficient at chip interface must remain low for minimum wear and reasonable surface finish.
- e. Cost and easiness in fabrication- the cost and easiness of fabrication should be within reasonable limits

State the composition physical properties and uses of various tool material:

The cutting tool materials are:-

- a. Carbon steels
- b. Medium alloy steels
- c. High speed steels
- d. Satellites
- e. Cemented carbides
- f. Ceramics
- g. Diamonds
- h. Abrasives

Carbon Tool Steels: Carbon tool steels have 0.08 to 1.4 % carbon + chromium + tungsten. Chromium is added to improve harden ability. Tungsten is added to improve wear resistance. Carbon tool steels lose their hardness at a temperature of about 250°. Cutting speeds with high carbon steel tools are about one third of those with HSS. Carbon tool steels are limited in use, limited to hand tools and other cutting tools operating at low cutting speeds.

High Speed Steels: High-speed steels are still a very important cutting tool material. High-speed steels retain a cutting edge for much longer periods and under much more rigorous conditions. It is possible to take heavy cuts at elevated temperatures without losing their hardness. HSS can be used up to 600°C. It has a high hot hardness. It possesses good strength and shock resistant properties. 18-4-1 is common one.

- a. **18 % Tungsten:** The ability to remain hard at high temperature is due to inclusion tungsten
- b. **4% Chromium:** With carbon forms very hard carbides
- c. **1% Vanadium:** Refines the grain structure and improves the shock resistance

d. 0.7 % carbon

HSS steel is used for the manufacture of :

- a. Single point tools
- b. Drills
- c. Reamers
- d. Milling cutters

Cemented Carbides: Cutting tools made of cemented carbides are the most widely used on account of their extreme hardness. A typical analysis of a carbide suitable for steel machining is 82% tungsten carbide, 10% titanium carbide and 8% cobalt. This coating of titanium carbide gives greater wear resistance and hence extended tool life.

Uses:

Titanium carbide is frequently used either on its own with a binder, or as a coating on a tungsten carbide tool.

Stellite:

Stellites are the trade name of a nonferrous alloy of cobalt, chromium and tungsten. The ranges of elements in these alloys is 40 to 48% cobalt, 30 to 35% Chromium & 12 to 19% tungsten. Material is not so hard at room temperature. Hardness above 1000F is greater than high speed steels. Hot hardness is higher than H.S.S at higher temperature.

Uses:

These materials are used extensively in some non-metal cutting applications such as rubbers, plastics.

Abrasive:

Abrasive grains in various forms, loose, bonded into wheels and extended in papers and cloths find wide application in industry. They are mainly used for grinding harder materials and where a superior finish is desired on hardened or unhardened materials.

Uses:

For most grinding operations there are two kinds of abrasives in general use namely aluminium oxide and silicon carbide. The aluminium oxide abrasives are used for grinding all high tensile materials, whereas Silicon Carbide abrasives are more suitable for low tensile materials.

Diamonds:

The diamonds used for cutting tools are industrial diamonds, which are naturally occurring diamonds. It has a low coefficient of friction. Hardness of the diamond is incompressible.

Uses: Diamonds are suitable for cutting very hard material such as glass, plastics, ceramics.

Ceramics:

The latest development in the metal cutting tools use Al₂O₃ generally referred to as ceramics. Ceramic tools are made by composing aluminium oxide powder in a mould at about 280 kg/cm² or more. The ceramic has extremely high compressive strength. It is quite brittle. Heat conductivity is very low. So generally no coolant is required while machining. The ceramic tools can retain strength and hardness up to 1200°C.

Uses:

These tool materials are used for turning, boring, etc operations at high speed.

CUTTING TOOL

Cutting tools:

In machining a cutting tool or cutter is used to remove the material from the W/P by means of shear difference

Cutting tool must be made of a material harder than the material which is to be cut and the tool must be to withstand the heat generated in the metal cutting process

The angle of cutting facer is also important, also the tool must have a specific geometry and clearance angles designed so that the cutting edge can contact the W/P surface .

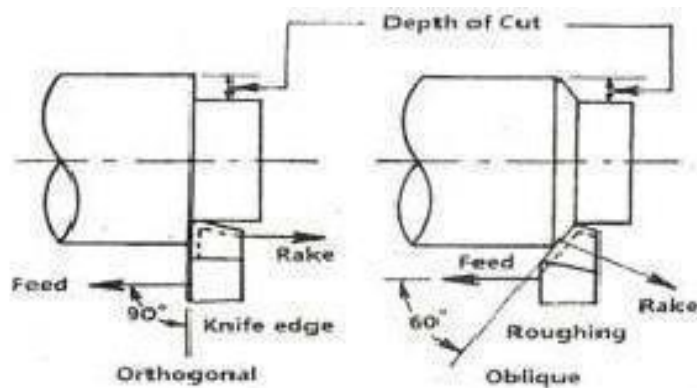

Figure Orthogonal and oblique cutting

Single point cutting tool

This type of cutting tools have only one cutting edge. These used for wide application of lathe, shaper planner, slitter, boring M/C

Multi point cutting tools

This type cutting tools have more than cutting edge. These are employed for wide application in twist drills, Reamers, tapes, milling cutters etc.

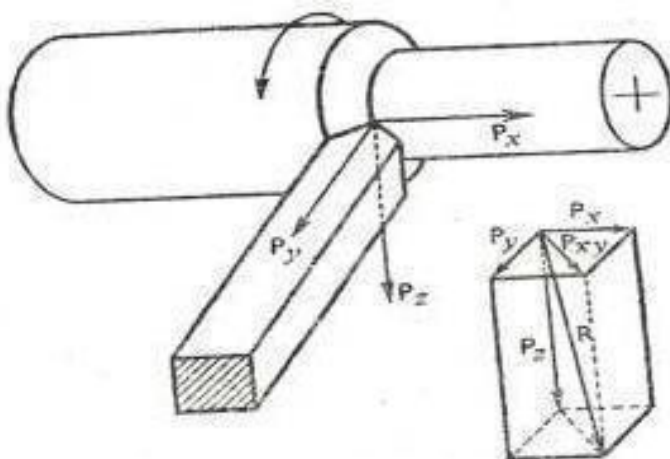

Figure Cutting forces in conventional turning process

Cutting action of hand tools

Chisel:

A chisel is a hand cutting tools which is shaped cutting edge of blade on its end, for carving, cutting a hard material such as wood, stone, metal by hand with the help of mechanical power.

In used the chisels are forced in to the material to linear relative The driving forced into the material may be manually applied by using a hammer.

In industrial use, a hydraulic ram or falling weight drives the chisel into the material to be cut .

Chisel is employed to use in wood work, metal working etc. In wood & stone working used for carving, cutting, shaving shaping, trimming.

In metal working process chisel use divided into two categories:

Cold chisel:

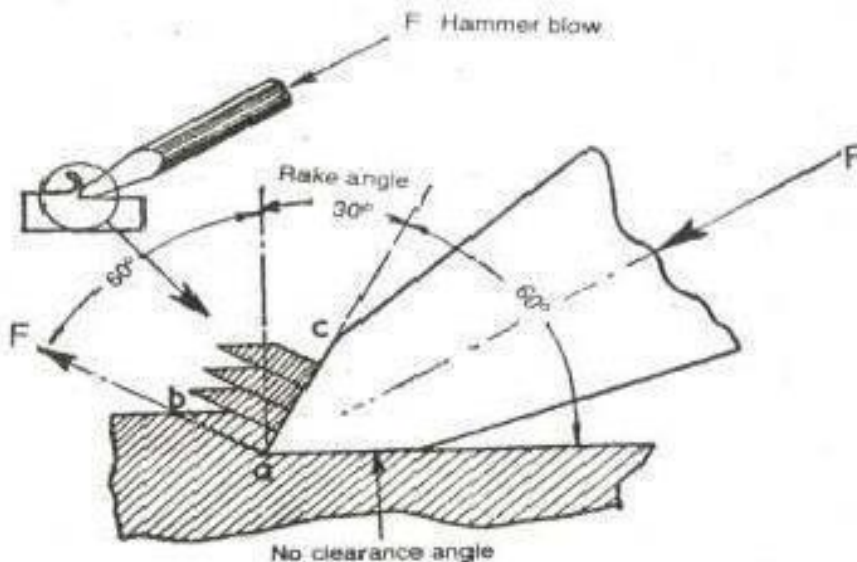

Figure Shearing action of a cold chisel

- It is made of from tempered steel
- Use for cutting cold metal.
- Used to remove waste metal in the situation where a smooth finish is not necessary or when other tools such as file, hacksaws cannot be used .

Hot chisel:

A hot chisel is used to cut metal that has been heated in a force to sustain the metal. Used to smooth the metals.

Hacksaw blade

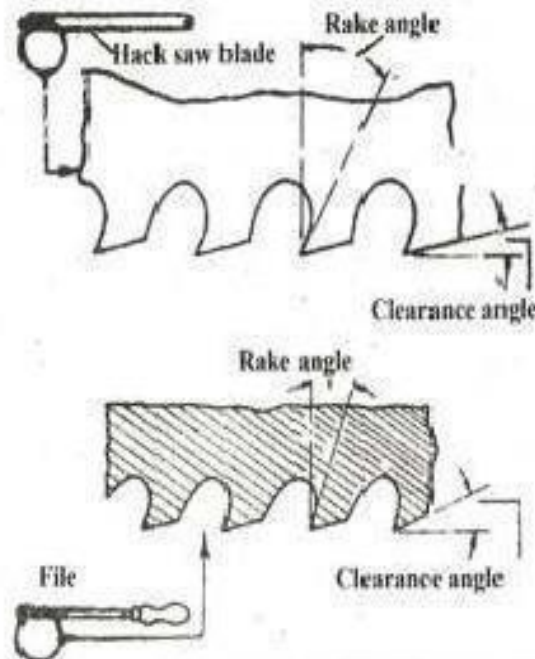

Figure Rake and clearance angles on hacksaw blade and file

Hacksaw blade is a fine toothed saw, originally principally for cutting metal. They can also cut various other materials such as plastic & wood. There are hand saw various & power various. When attached to a C-shaped frame which holds a blade under tension. The frames may be adjustable to accommodate blades of different sizes.

The pitch of the teeth can be anywhere from 14 to 32 per inch for a hand blade & for large power hack saw blade there are 3 tpi. As hack-saw teeth are so small, they are set in a wave set. As the blades are normally quite brittle, so proper care should be taken to prevent fracture of the blade.

On hack-saw the blade can be mounted with the teeth facing toward or away from the handle. Resulting in cutting action on either pushes or pull stroke. In normal use, cutting vertically downwards with work held in a bench, vice, the saw blade should be set to be face forward.

Die:

Dies are used to cut the external thread on the rod or pipe end. Dies are made of high carbon steel or HSS. The process of cutting external thread by dies is called dieing.

Dieing is also known as die cutting, is a process which cuts stock without formation of chips or the off during or melting.

The die cutting action can be controlled by electric, hydraulic, pressurized or manual surfaces.

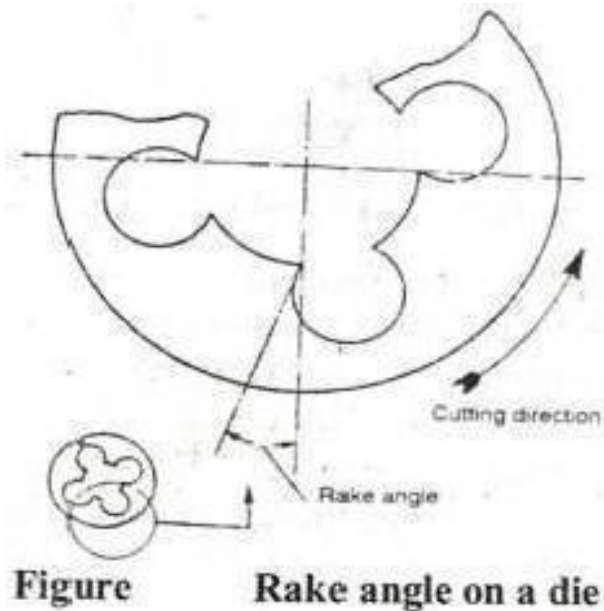

Reamer:

It is a multiple edge cutting tools. The process of enlarging the hole is called reaming. There are many different types reamer and there may be designed for used as a hand tool or in a M/C tool such as milling M/C or drill press.

A typical reamer consists of a set of parallel straight or helical cutting edge along the length of a cylindrical body

Each cutting edge is grounded at a slight angle and with slight undercut below the cutting edge

This may be used to remove small amount of material. Reamers are made of high Carbon or Plain Carbon Steel

Reamers are of two types

- Hard Reamers
- Machine Reamers

Machining Process Parameters:

Factors affecting tool life:

The life of a tool is affected by many factors such as: cutting speed, feed, depth of cut,

chip thickness tool geometry, material of cutting fluid, and rigidity of the machine

Cutting Speed:

The cutting speed can be defined as the relative surface speed between the tool and the job or the amount of length that will pass the cutting edge of the tool per unit of time.

Or

It may be defined as the speed which the cutting edge pass over the material. It is expressed in meters per min (mpm).

Feed:

It is defined as the relation by small movement per cycle of the cutting tool, relative to the workpiece in a direction which is usually to the cutting speed direction.

Or

It is the distances the tools advances into or along the work piece. Each time the tool point passes a certain position in its travel over the surface. It is expressed as mm/tooth.

Depth of cut:

The depth of cut is the thickness of the layer of metal removed in one cut or pass, measured in a direction perpendicular to the machined surface.

Or

It is the vertical distance the tool advances into the work piece during one revolution of job it is expressed in mm.

Single point cutting tool terms:

- (1) Shank: The shank is the main body of the tool.
- (2) Nose: The nose is the part of the cutter bit which is shaped to produce the cutting edges.
- (3) Face: The face of the cutter bit is the surface at the upper side of the cutting edge on which the chip strikes as it is separated from the workpiece.
- (4) Side: The side of the cutter bit is the near-vertical surface which, with the end of the bit, forms the profile of the bit. The side is the leading surface of the cutter bit used when cutting stock.
- (5) Base: The base is the bottom surface of the shank of the cutter bit.
- (6) End: The end of the cutter bit is the near-vertical surface which, with the side of the bit, forms the profile of the bit. The end is the trailing surface of the cutter bit when cutting.

Important angles of a Single Point Cutting Tool:

Back Rake Angle : It is the angle between the face of the tool and a line parallel to the base of the tool and measured in a plane perpendicular to the side of the cutting edge. The angle is +ve – If side cutting edge slopes downwards from the point towards the shank-ve – if the slope of the side cutting edge is reverse.

Side Rake Angle : It is the angle between the tool face and a line parallel to the base of the tool and measured in a plane perpendicular to the base and side cutting edge. This angle gives slope of the face of the top from the cutting edge.

The angle is – ve – if the slope is towards the cutting edge +ve - If the slope is away from the cutting edge

Side Relief Angle : It is the angle between the portion of the side flank immediately below the side cutting edge and a line perpendicular to the base of the tool measured at right angle to the side flank.

End Relief Angle : It is the angle between the portion of the end flank immediately below the side cutting edge and a line perpendicular to the base of the tool measured at right angle to the end flank.

Side Cutting Edge Angle : The angle between the side cutting edge and side of the tool Shank

End Cutting Edge Angle : This is the angle between the end cutting edge and a line normal to the tool shank

Lip Angle : It is also called cutting angle. It is the angle between the face and end surface of the tool.

Nose Angle : It is the angle between the side cutting edge and end cutting edge.

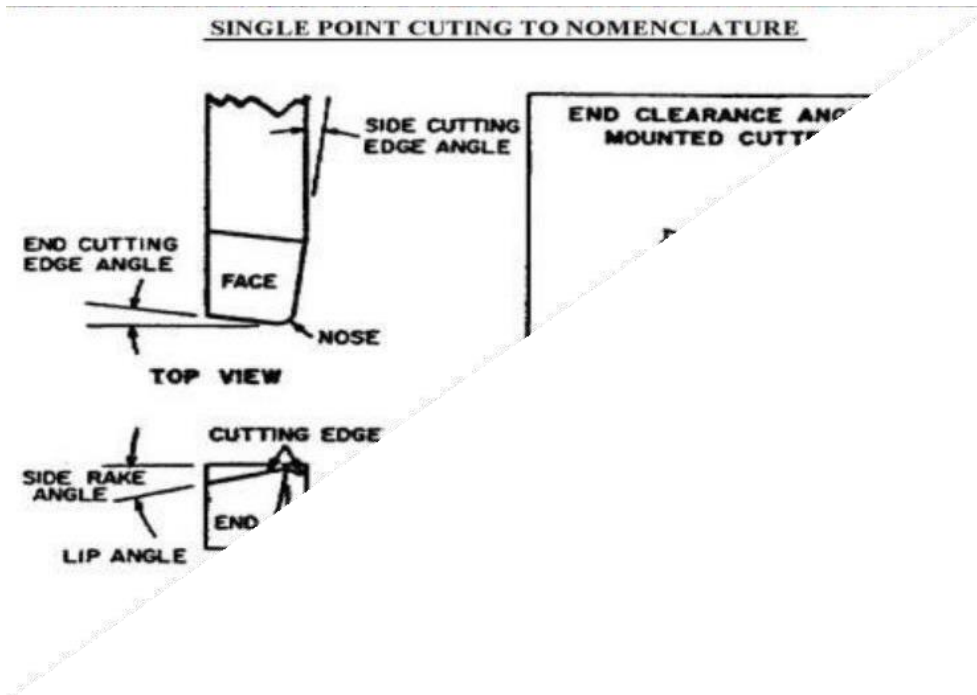

Purpose of tool angles

Side cutting edge angle (Cs):

cs– It is the angle which prevents interface as the tool enters the work material. This angle affects tool life and surface finish

End cutting edge angle (Ce):

Ce – It provides a clearance or relief to the end of the cutting edge to prevent rubbing or drag between the workpiece surface and the cutting tool edge .

Side Rack angle:

These angles are provided so that the flank of the tool clears the workpiece surface and there is no rubbing between them

Back race angle

The rake angle is small for cutting hard materials and large for cutting soft ductile materials. It may be +ve, –ve OR zero.

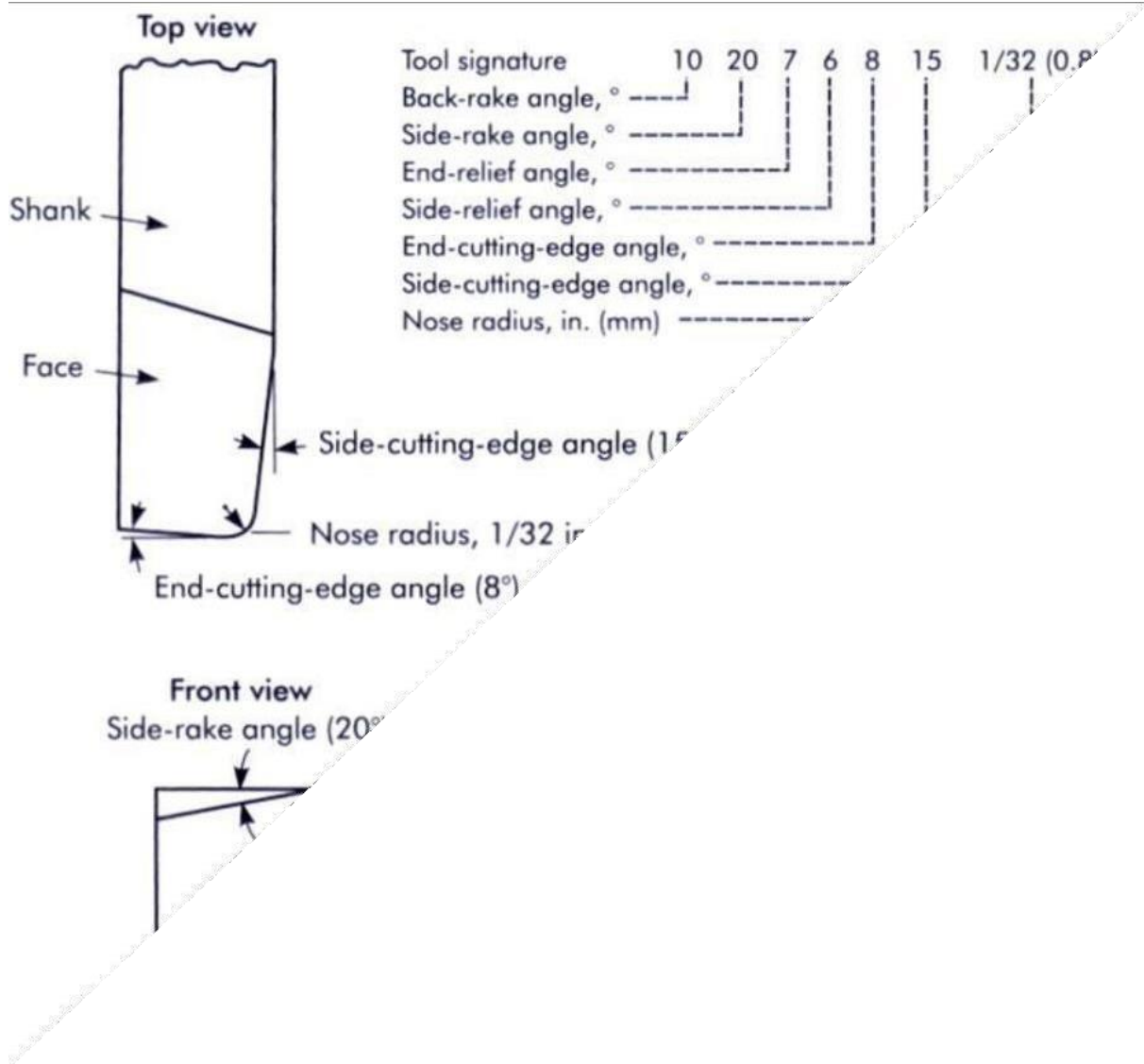

Coolants & lubricants:

Cutting fluid sometimes referred to as lubricants or coolants and liquids and gases applied to the tool and work piece to assist in the cutting operations.

Purpose of cutting fluid:

1. To cool the tool
2. To cool the work piece
3. To lubricate and reduce friction
4. To improve surface finish
5. To protect the finished surface from corrosion

6. To cause chips break up into small parts
7. To wash the chips away from the tool

Properties of cutting fluids:

1. High heat absorption for readily absorbing heat developed.
2. Good lubricating qualities to produce low-coefficient of friction.
3. High flash point so as to eliminate the hazard of fire
4. Stability so as not to oxidize in the air
5. Neutral so as not to react chemically
6. Colorless so as not to produce any bad smell even when heated.
7. Harmless to the bearings.
8. Harmless to the skin of the operators
9. Non-corrosive to the work or the machine
10. Transparency so that the cutting action of the tool may be observed.
11. Low viscosity to permit flow of the liquid
12. Low priced to minimize production cost.

LATHE MACHINE

CONSTRUCTION AND WORKING OF LATHE MACHINE:

Lathe machine is a machine that holds the workpiece on a chuck and tool on a toolpost, the lathe machine rotates workpiece about an axis to perform different operations such as turning, facing, chamfering, thread cutting, knurling, drilling and more with tools that are applied to the workpiece to design an object with symmetry about that axis.

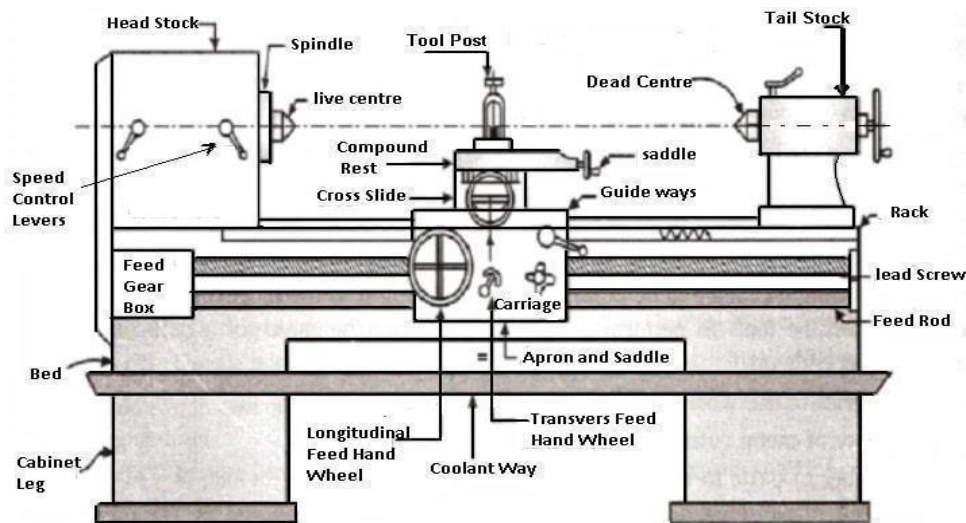

LATHE MACHINE

The main function of a lathe is to remove the material from the work piece. In a lathe machine, the tool is held and a workpiece is rotating about an axis rotation to perform various operations with different tools.

The lathe machine is primarily used to produce cylindrical surfaces and plane surfaces at a right angle to the axis of rotation. It can also produce tapers. Most suitable lathes can also be still using for produce most solids of revolutions, plane surfaces & screw threads etc.

MAJOR COMPONENTS OF A LATHE AND THEIR FUNCTION

The following are the main components of lathe machine.

1. Bed
2. headstock
3. Carriage
4. Feed mechanism
5. Tailstock
6. Screw or thread cutting mechanism
7. Feed rod
8. Lead screw

Bed

The lathe bed is the base of the machine, which is a solid structure. It should be provided strictly under heavy pressure. On top of the bed, has the V-type of guideways include the angle of 90°.

There are two guideways provided, inner ways and outer ways, which are accurately machined to make them parallel to the axis. The lathe should take up the varies vibrations, which are causing due to different types of force. The guideways provide sliding surfaces to the carriage and the tailstock.

The lathe bed must-resist stresses due to the results of two important forces,

The downward cutting force on the tool

The force tending to move the tool away from the workpiece in a horizontal direction

Headstock

It is located on the left-hand side of the lathe bed. It has a hollow spindle and the different types of mechanism for driving and changing the speed of the spindle.

In this case, the speed increases when the belt is shifted from larger to smaller diameter pulleys. The spindle is made up of nickel, chrome steel and carbon steel. The front end of the spindle hole is taper for holding the centres perfectly.

Tailstock

The tailstock is located on the right-hand side of the lathe bed. The tailstock supports the other end of the workpiece when it is machining between two centres.

It holds the tool rigidly and perfectly for performing operations such as drilling, reaming, tapping, and boring. It can move along the guideways and can clamp in any position on the bed.

The tailstock is consist of the dead centre, spindle, adjusting screw, hand wheel, etc. The spindle can move forward and backward of the body called barrel by means of a handwheel. The keyway is provided on the inside surface of the barrel to hold the dead centre.

carriage

The carriage is one of the most important parts of the lathe tool and it will serve as a supporting, moving and controlling part of the cutting tool.

It consists of the following parts:

Saddle

It is 'H' shaped. The saddle fits over the bed and slides along the guideways by carrying the cross slide and tool post. It can lock in any position in its movement.

Cross Slide

It is an attachment to the saddle and to the compound rest. The cross slide moves by the turning handwheel. Transverse movement is obtained when the nut mounted on the feed screw is engaged with the binder screw of the cross slide.

When a taper turning attachment is used the binder screw is open to disconnect the cross slide from crossfeed screw and the cross slide is attached to the guide block. Cross slide can move automatically when the pinion is keyed to the crossfeed screw is in mesh with the apron gearing.

Compound rest

It is a circular base, graduated in degrees and it is used to obtain angular cuts and tapers of the variable cross-section. It consists of compound slide handwheel, compound slide feed screw, compound slide nut. The compound slide handwheel is mainly used in taper turning operation to give the feed.

Tool post

The tool post is placed above the compound rest and it holds the tool firmly. There are different types of tool post,

- Single screw tool post
- Four-way tool post
- Eight-way tool post

feed mechanism

The amount of the tools relative to the workpiece is called 'Feed'.

A lathe tool has 3 types of feed

- **Longitudinal feed:** Here the tool moves parallel to the lathe axis. It is affected by means of the carriage movement.
- **Crossfeed:** Here the tool moves at right angles to the lathe axis.

Angular feed: By adjusting the compound slide and swivelling it to the required angle to the lathe axis

Lathe Machine Operation

Turning:

Turning is the operation of removing the excess material from the workpiece to produce a cylindrical surface to the desired length. The job held between the centre or a chuck and rotating at a required speed. The tool moves in a longitudinal direction to give the feed towards the headstock

Taper Turning:

- A "taper" is the uniform increase or decrease in the diameter of the workpiece and measured along with its length.
- Taper turning means to produce a conical shape by a gradual reduction in diameter from a cylindrical workpiece.

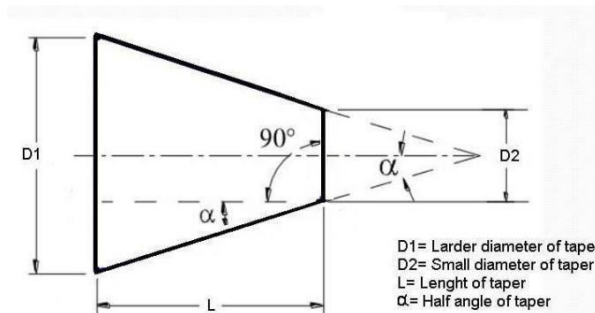

The amount of taper in the workpiece is usually specified on the basis of the difference in diameter of the taper to its length. It is known as a cone and it is indicated by the letter K.

It has the formula $K = D-d / L$ to produce the taper on the workpiece.

- D = Larger diameter of taper.
- d = Small diameter of taper.

Facing:

It is an operation of reducing the length of the workpiece by feeding the perpendicular to the lathe axis. This operation of reducing a flat surface on the end of the workpiece. For this operation, The cutting edge of the tool should set to the same height as the centre of the workpiece.

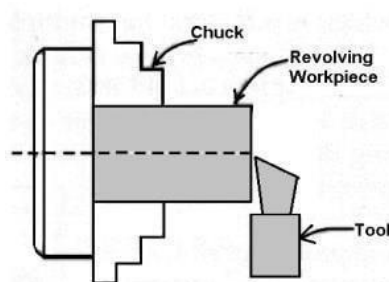

Facing Operation

- Facing consist of 2 operations
 - Roughing: Here the depth of cut is 1.3mm
 - Finishing: Here the depth of cut is 0.2-0.1mm.

Knurling operation:

It is an operation of obtaining a diamond shape on the workpiece for the gripping purpose.

This is done to provide a better gripping surface when operated by hands. It is done using a knurling tool. The tool consists of a set of hardened steel roller, and it is held rigidly on the toolpost.

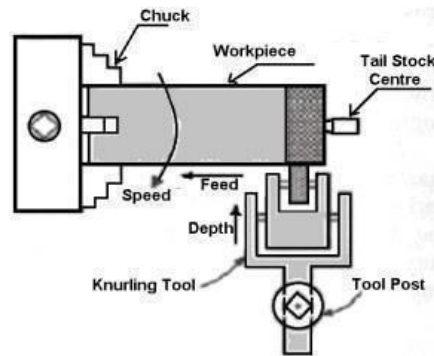

Knurling

Knurling is done at the lowest speed available on a lathe. It is done on the handles and also in case of ends of gauges. The feed varies from 1 to 2 mm per revolution. Two or three cuts may be necessary to give the full impression.

Grooving:

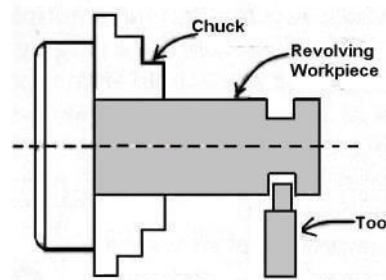

Grooving

It is the process of reducing the diameter of a workpiece over a very narrow surface. It is done by a groove tool. A grooving tool is similar to the parting-off tool. It is often done at the end of a thread or adjacent to a shoulder to leave a small margin.

Thread Cutting:

It is the important operation in the lathe to obtain the continuous "helical grooves" or "threads". When the threads or helical grooves are formed on the out surface of the workpiece is called external thread cutting. When the threads or helical grooves are formed on the inner surface of the workpiece is called internal thread cutting. The workpiece is rotating between the two centers i.e., live centre and dead centre of the lathe.

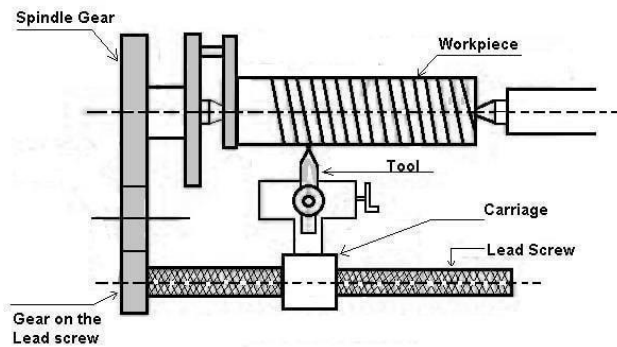

Thread Cutting

Here the tool is moved longitudinally to obtain the required type of the thread. When the tool is moved from right to the left we get the left-hand thread. Similarly, when the tool is moved from left to the right we get the right-hand thread..Here the motion of the carriage is

Provided by the lead screw. A pair of change gears drives the lead screw and by rotating the handle the depth of cut can be controlled.

INTERNAL MACHINING

Drilling:

Drilling is the operation of producing a cylindrical hole in a workpiece. It is done by a rotating tool, the rotating side of the cutter, known as drilling drill. In this operation, The workpiece is revolving in a chuck or a faceplate and the drill is held in the tailstock drill holder or drill chuck.

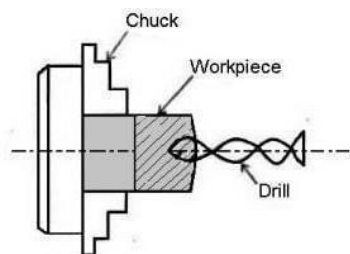

Drilling

The feeding is adopted is affected by the movement of the tailstock spindle. This method is adopted for the drilling regular-shaped workpiece.

Reaming:

Reaming is the operation of finishing and sizing a hole which has been already drilled or bored. The tool is used is called the reamer, which has multi-plate cutting edges.

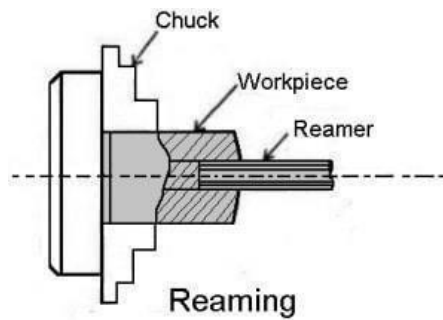

The reamer is held on the tailstock spindle; either directly or through a drill chuck and is held stationary while the work is revolved at a very slow speed.

Boring:

Boring is the operation of enlarging the hole which is already drilled, punched or forged. It cannot produce a hole. Boring is similar to the external turning operation and can be performed in a lathe. In this operation, the workpiece is revolved in a chuck or a faceplate and the tools which are fitted to the tool post is fed into the work.

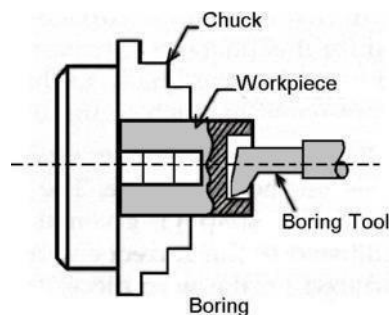

It consists of a boring bar having a single point cutting tool which enlarges the hole. It also corrects out of roundness of a hole. This method adopted for boring small-sized works only. The speed of this process is slow.

Tapping:

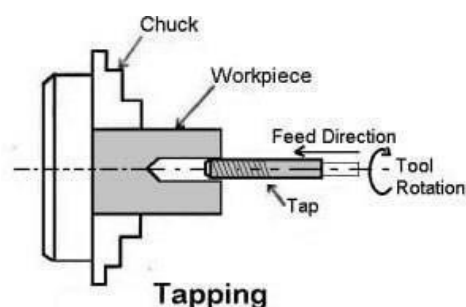

Tapping is the operation of cutting internal threads of small diameter using a multipoint cutting tool called the tap. In a lathe, the work is mounted on a chuck or on a faceplate and revolved at a very slow speed. A tap of required size held on a special fixture is

mounted on the tailstock spindle.

Safety measures during machining:

Some safety precautions should be needed while working on lathe.

- Before operating the machine, one should fully understand its operations controls and how to stop it.
- All gears and gear ends of the lathe should be properly guarded.
- Safety goggles are preferred to avoid damage to eyes by flying chips.
- Avoid wearing rings, bracelet or watch.
- Machine should not be left running and operator should be alert during a job.
- Before starting a lathe spindle by power, spindle should be rotated by one revolution by hand to make it sure that no fouling is there.
- Safe distance from revolving chuck should be maintained.
- Tools and instruments should not be placed over lathe bed.
- Sliding parts of the lathe should be cleaned and lubricated periodically.
- Chips should never be removed by hand. It can be removed by brush.
- Before starting the machine, the work should be clamped properly.
- Before moving the carriage, the carriage clamping screw should be unlocked.
- On hearing unusual noise, machine should be stopped immediately and should not be operated till the fault is clear.

CAPSTAN AND TURRENT LATHE

Capstan & Turret lathes:

A capstan or a turret lathe is a production lathe used to manufacture any number of identical pieces in the minimum time. The main feature is the six sided block mounted on one end of the bed replacing the normal tailstock six tools can be mounted at on cross slide two tool posts are mounted, one in the front and the other in the rear. Each one can hold four tools .Thus the total carrying capacity is a maximum 14 tools

Difference between CAPSTAN &TURRET and an ENGINE LATHE

CAPSTAN &TURRET	ENGINE LATHE
1. The head stock possesses wider range of speeds and in heavier in construction it require 15 hp power to drive the spindle.	1. It requires 3hp to drive the spindle.
2. The tool post mounted or the cross slide is a four way & a rear tool post is mounted on the rear side which also holds 4 tools.	2. In engine lathe one tool can be mounted at one time for different operation.
3. In turret lathe, the tail stock is replaced by a turret which is a hexagonal block which contains 6 tools on each face.	3. It can accommodate one tool of limited size.
4. The feed movement of each tool set on square or hexagonal turret is regularity by stops & feed strips.	4. The feed movement is given by hand.
5. Combination cuts can be taken by mounted two or more tools on the same face of the turret.	5. Combination cuts cannot be done.
6. The labour cost is less.	6. Labour cost is more.
7. The threads are cut by die and taps	7. The threads are cut by lead screw.

The Capstan or Ram Type Lathe

The capstan or ram type lathe is shown in the figure. This machine carries the hexagonal turret on ram or a short slide.

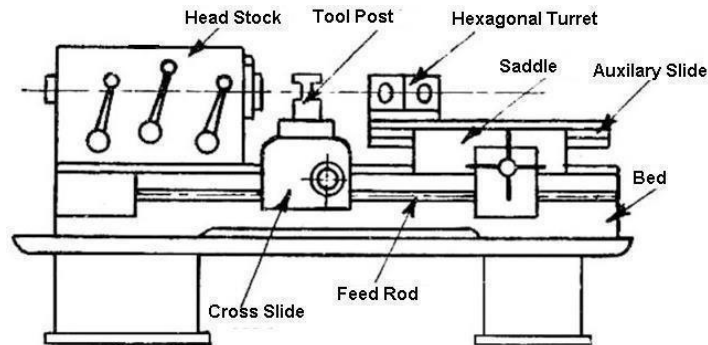

CAPSTAN LATHE MACHINE

The ram slides longitudinally on a saddle positioned and clamped on lathe bedways. This type of machine is lighter in construction and is suitable for machining bar of smaller diameter.

The tools are mounted on the square turret and 6 faces of the hexagonal turret.

The feeding movement is obtained when the ram moves from left to the right. And when the ram is moved backwards the turret indexes automatically and the tool mounted on the next face comes into operation.

The Turret or Saddle Type Lathe

The turret lathe is another type of lathe machine. It is used for repetitive production of same duplicate parts, which by the nature of their cutting process are usually replaceable. The hexagonal turret as shown in the figure.

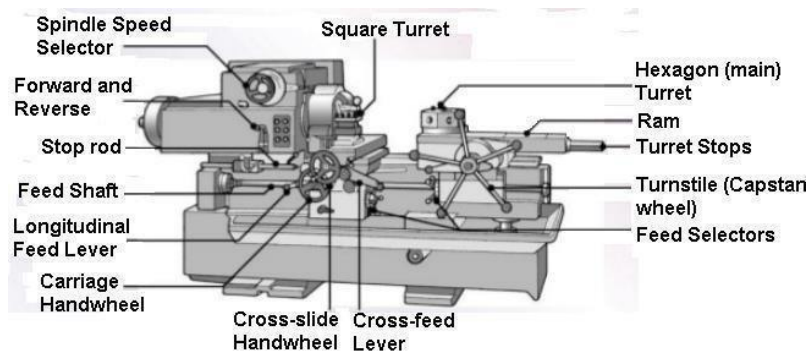

TURRET LATHE MACHINE

It is mounted directly on a saddle and the whole unit moves back and forth on the bed-ways to apply feed.

This type of turret lathe machine is heavier in construction. It is particularly adapted for larger diameter bar work and chucking work. The machine can take in longer workpieces

than that in a capstan lathe.

Difference between capstan & turret lathe:

Capstan lathe	Turret lathe
<ol style="list-style-type: none">1. Its turret head is mounted in slide, which moves on the guide ways produced on the saddle.2. For feeding the tool to the work, the saddle is fixed at convenient distance from the work.3. It is suitable for smaller size & lighter jobs. It is not suitable for heavy cutting condition.4. It is suitable to work for smaller bar upto 60 mm dia.5. The turret head may hexagonal or circular.6. It is smaller in size compound to turret lathe.7. The tool traverse is faster and offer less fatigue to the hands of the operator.	<ol style="list-style-type: none">1. Its turret to head is mounted directly on the saddle.2. For feeding the tool to the work, the entire saddle unit is moved.3. It is suitable for long and heavy work and severe cutting condition.\4. It is used to work for large size bar upto 200mm dia.5. Turret head is hexagonal.6. It is large in size as compared to capstan lathe.7. The tool feeding is relatively slower and provide more fatigue to operator hands.

Principle Parts of Capstan And Turret Lathes

The turret lathe has essentially the same parts like the engine lathe except for the turret and complex mechanism incorporated in it for making it suitable for mass production work.

1. Bed.
2. Headstock.
3. Cross slide and saddle.
4. The turret saddle and auxiliary slide.

1. Bed

The bed is a long box like casting provided with accurate guideways upon which are mounted the carriage and turret saddle. The bed is designed to ensure strength, rigidity and permanency of alignment under heavy duty services.

2. Headstock

The headstock is a made up of large casting. It is located at the left-hand end of the bed. The different types of headstocks in capstan and turret lathe are as follows:

1. Step cone pulley driven headstock.
2. Direct electric motor driven headstock.
3. All geared headstock.
4. Preoptive or preselective headstock.

3. . Cross-slide and saddle

In small capstan lathes, hand-operated cross slide is used which are clamped on the lathe bed at the required position. The larger lathes and heavy-duty turret lathes are equipped with usually two designs of the carriage.

1. Conventional type carriage
2. Side hung type carriage

4. The turret saddle and auxiliary slide

In a capstan lathe, the turret saddle bridges the gap between two bed-ways, and the top face is accurately machined to provide a bearing surface for the auxiliary slide.

The saddle is adjusted on lathe bed-ways and clamped at the desired position. The hexagonal turret is mounted on the auxiliary slide.

In a turret is directly mounted on the top of the saddle and any movement of the turret is affected by the movement of the saddle.

The movement of the turret may be effected by hand or power. The turret is a hexagonally shaped tool holder intended for holding six or more tools.

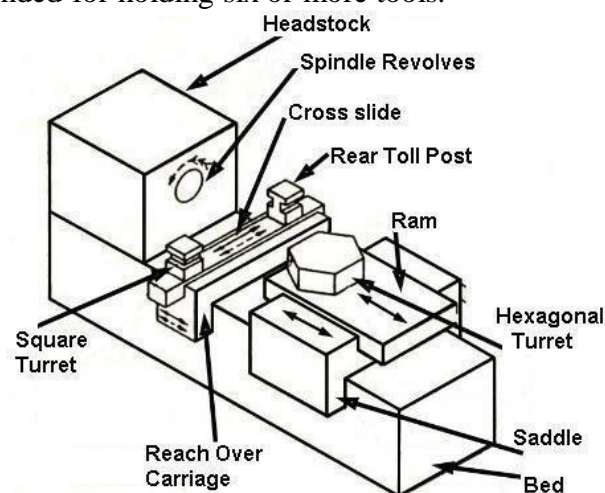

Each face of the turret is accurately machined. Through the centre od, each face accurately bored holes are provided for accommodating shanks of different tool holders.

The centre line of each hole coincides with the axis of the lathe when aligned with the headstock spindle. In addition to these holes, there are four tapped holes on each face of the turret for securing different tool holding attachments. At the centre of the turret on the top

of it, there is a clamping lever which locks the turret on the saddle.

Six stop bars mounted on the saddle which restricts the movement of each tool mounted on each face of the turret to be fed to a pre determined amount for duplicating workpiece.

After one operation is completed, as the turret is brought back away from the spindle nose, the turret indexes automatically by a mechanism incorporated on the bed and in turret saddle, so that the tool mounted on the next face is aligned with the work.

Turret head indexing mechanism:-

This is an inverted plan of turret assembly. The turret is mounted on the spindle. The index plate, the, bevel gear and an indexing ratchet are keyed to the spindle. The plunger fitted within the housing and mounted on the saddle locks the index plate by spring pressure and prevents any rotary movement of the turret as the tool feeds into the work.

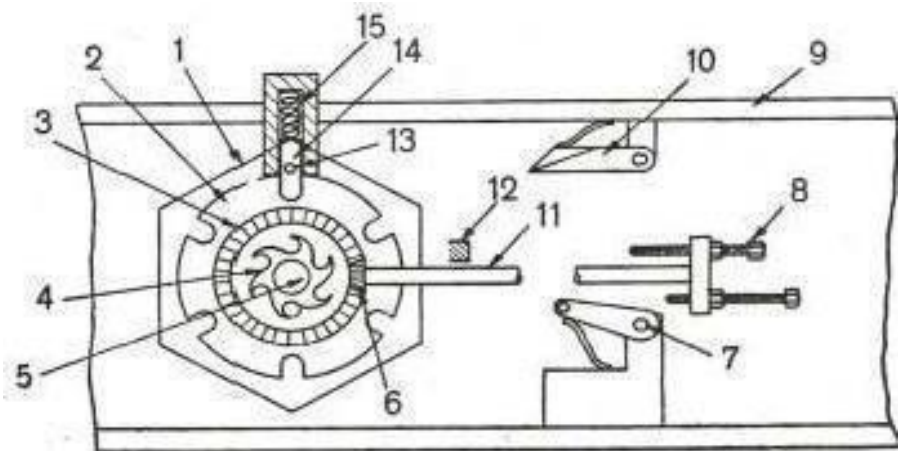

Figure 4.5 Turret indexing mechanism

1. Hexagonal turret, 2. Index plate, 3. Beveled gear, 4. Indexing ratchet, 5. Turret spindle, 6. Beveled pinion, 7. Indexing pawl, 8. Screw stop rods, 9. Lathe bed, 10. Plunger actuating cam, 11. Pinion shaft, 12. Stop, 13. Plunger pin, 14. Plunger, 15. Plunger spring.

A pin is fitted on the plunger projects out of the housing. An actuating cam and the indexing pawl are attached to the lathe bed at desired positions. Both the cam and the pawl are spring loaded. As the turret reaches the backward position, the attaching cam lifts the plunger out of the groove in the index plate due to the riding of the pin on the beveled surface of the cam and thus. unlocks the index plate. When the index plate or turret rotates through one sixth of revolution, the pin and the plunger drops out of the cam and the plunger locks the index plate at the next groove. The turret is thus indexed by one sixth of revolutions and again backed into the next position.

Automatically. The turret holds the next tool is now fed forward and the pawl is released from the ratchet plate by the spring pressure. The bevel opinion meshes with the bevel gear mounted on the turret spindle. The extension of the pinion shaft carries a plate holding six adjustable stop rods. As the turret rotates through one sixth of the revolution, the bevel gear causes the plate to rotate. The ratio of the teeth between the pinion and the gear are so chosen that when the tool mounted on the face of the turret is indexed to bring it to the cutting position, the particular stop rod for controlling the longitudinal travelling of the tool is aligned with the stop. The setting of the stop rods for limiting the feed of each operation may be adjusted by unscrewing the lock nuts and rotating the stop rods on the plate. Thus, six stop rods may be adjusted for controlling the longitudinal travel of tools mounted on six faces of the turret.

Bar feeding mechanism:-

On the capstan and turret lathes, some arrangements is need to be feed the bar stock through the collet or chuck after each finished work piece is parted off. Bar may be fed by hand also but has a safety measure one has to stop the machines first for every feeding of bar. It also wastes lot of time.

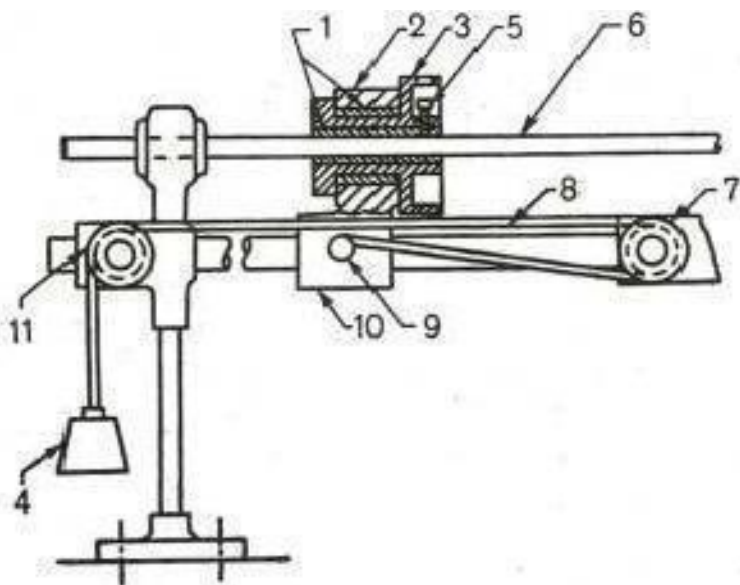

Figure 4.6 Bar feeding mechanism

- 1. Chuck bush, 2. Sliding bracket body, 3. Bar chuck, 4. Weight, 5. Bar chuck set screw, 6. Bar, 7, 11, Pylley, 8. Chain, 9. Pin on the sliding bracket, 10. Sliding bracket

In this method the bar is push forward as soon as it release from the collect without stopping the lathe. A bar feeding mechanism is fitted with a capstan lathe is the back side of lathe. Bar is fed against the rotating sleeve and the collet chuck. The bar stock passes through the spindle of the collet chuck. One end of the rope is connected with the sleeve and the other end is attached with a weight. Length of the bar as soon as the collet is opened by operating the control lever, the bar is release and it automatically rushed out of the collet and strike with the bar stop The bar stop mounted on the capstan head for the purpose of getting the required bar length projecting out of the collet. The collet lever is again operated to close the collet and hold the bar tightly

SHAPER MACHINE

Shaper:-

The shaper is a reciprocating type of machine tool intended to produce flat surfaces. The surface may be horizontal, vertical or inclined

Working principle:-

The job is fixed rigidly in a suitable vice or directly clamped on the machine table. The tool is held in the tool post mounted on the ram of the machine. This ram reciprocates to and fro, and in doing so, makes the tool to cut the material in the forward stroke. No cutting takes place during the return stroke of the ram. It is called idle stroke. The job is given an intended

Applications of a Shaper Machine

This is used for machining straight and flat surfaces.

For gear teeth and other internal splines.

For the blind holes, the gear tooth cutting can be done.

Used for dovetail sliders.

This is a perfect device to get the smoothness of a rough surface.

It is also used for electric discharge machining.

In the irregular shape holes with tight corners cannot be made with milling or with other machining processes. The machine can create these types of hole.

This is the information about various shaper machine.

Parts of Shaper Machine

The following are the main **parts of shaper machine**:

1. Base
2. Column
3. Cross-rail
4. Table

5. Ram

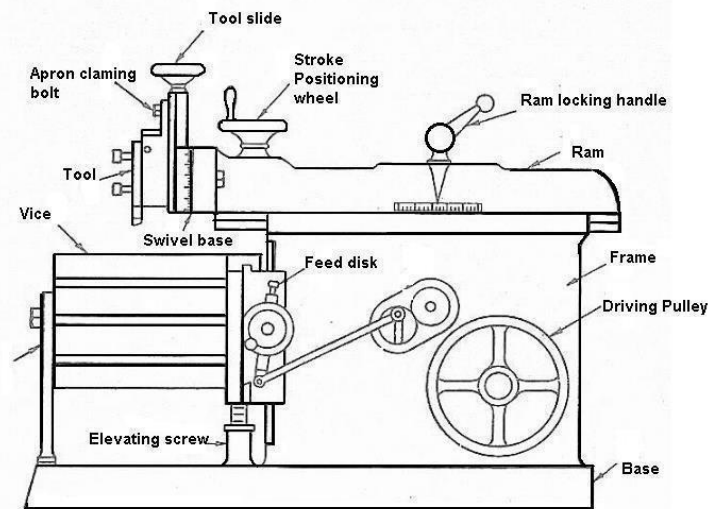

1. Column

- This is made of cast iron, which is a box-like and is mounted on the base.
- two accurately machined guideways are provided on the top of the column on which the ram reciprocates.
- The column acts as a cover to the drive mechanism and also supports the reciprocating ram and the worktable.

2. Cross-rail

- Cross rail is mounted on the front vertical surface of the column on which saddle is mounted.
- The vertical movement is given to the table by raising or lowering the cross rail using the elevating screw.
- The horizontal movement is given to the table by moving the saddle using the crossfeed screw.

3. Table

- The table is bolted to the saddle and receives crosswise and vertical movements from saddle cross rail.
- T-bolts are used for clamping on top and sides.
- The table can be swiveled at any required angle.
- In a universal shaper, the table may be swiveled on a horizontal axis and the upper part of the table may be fitted up or down.
- In heavier type shaper the table clamped with table support to make it more rigid.

4. Ram

- The ram reciprocates on the column guideways and carries the tool head with a single-point cutting tool.
- the tool head is in the clapper box, which causes cutting action only in a forward stroke of the ram and sliding movement of the tool in the reverse stroke of the ram.
- the depth of cut or feed of the tool is given by down feed screw.
- The tool head has swivel base degree graduations, which helps to move the tool head to any desired inclination for machining inclined surfaces on the workpieces.

5. Base

- The base is hollow casting made of cast iron to resist vibration and on which all parts of the shaper are mounted.
- It is so designed that it can take up the entire load of the machine and the forces set up by cutting tool over the work.

Types of Shaper Machines

Following are the different **types of shaper machines**.

1. Based on the type of driving mechanism.
 1. Crank type shaper.
 2. Geared type shaper.
 3. Hydraulic type shaper.
2. Based on ram travel.
 1. Horizontal shaper
 2. Vertical shaper.
3. Based on the table design.
 1. Standard shaper.
 2. Universal shaper.
4. Based on cutting stroke.
 1. Push cut type
 2. Draw cut type

Bases on the Type of Driving Mechanism

Crank Type Shaper Machine

These are very common types of shaper machines, which is used to hold the workpiece on the table. The tool is reciprocating in motion equal to the length of the stroke desired while the work is clamped in position on an adjustable table.

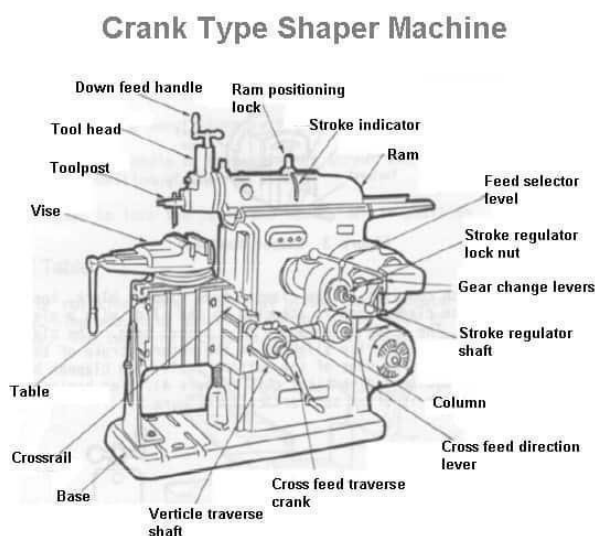

In construction, the crank shaper employs a crank mechanism to change the circular motion of a large gear called "bull gear" incorporated in the machine to reciprocation motion of the ram. It uses a crank mechanism to convert the circular motion of the bull gear into reciprocating motion of the ram. The ram carries a tool head at its end & provides the cutting action.

Gear Type Shaper Machine

In these types of shaper machines, the ram is reciprocating. The ram is affected due to reciprocating motion with the rack and pinion. This type of shaper machines is not widely used in any industry.

Hydraulic Shaper Machine

In these types of shaper machines, the reciprocating motion of the ram is provided by the hydraulic mechanism. The Hydraulic shaper uses the oil under high pressure. The end of the piston rod is connected to the ram.

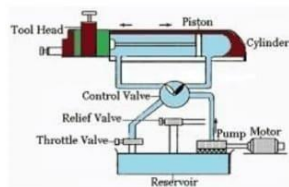

Hydraulic Type Shaper Machine

The high-pressure oil first acts on one side of the piston and then on the other causing the piston to reciprocate and the motion is transmitted to the ram. The main advantages of this type of shaper machine are that the cutting speed and force of the ram drive are constant. From start to end of the cut without making noise and operates quietly.

Based on Ram Travel

Horizontal Shaper Machine

In these types of shaper machines, the ram is reciprocating. The ram holding the tool in a horizontal axis and reciprocates. This type of shaper is used for the production of flat surfaces, external grooves, keyways etc.

Vertical Shaper Machine

In these types of shaper machines, the ram reciprocates in a vertical plane. In this, the table holds the workpiece. Vertical shapers may be crank driven, rack-driven, screw-driven or hydraulic power driven. The vertical shaper is very convenient for machining internal surfaces, keyways, slots or grooves. The workpiece can move in any given directions such

as the cross, longitudinal or rotary movements. This type of shaper is suitable for machining internal surfaces, slots & keyways.

Based on The Table Design.

Standard Shaper Machine

In this types of shaper machines, the table has only two movements, vertical and horizontal, to give the feed. That's why it known as standard shaper machine. Here the table is not supporting at the outer end.

Universal Shaper Machine

In this types of shaper machines, in addition to the two moments i.e. vertical and horizontal, the table can be moving in an inclined axis and also it can swivel on its own axis.

Since the workpiece mounted on the can be adjusted in different planes, the shaper os suitable for a different type of operations and is given the name "Universal". This type of shaper is commonly using the tool room works.

Based on Cutting Stroke

Different types of shaper machine based on cutting stroke.

Push cut Shaper Machine

In these types of shaper machines, the metal is removed in the forward motion of the ram. This is commonly used types of shaper machines.

Draw cut Shaper Machine

In these types of shaper machines, the metal is removed in the backward motion of the ram. In this shaper, the tool is fixed in the tool head in the reverse direction so that it provides the cutting action in the reverse stroke of the ram.

Automatic Table feeding mechanism of shaper

The automatic feed mechanism of the table is very simple. This is done by rotating a ratchet wheel, mounted at the crossfeed screw. This enables a corresponding equal rotation of the crossfeed screw after each stroke.

Arrangement of parts

It consists of a slotted disc, which carries a T-slot, as shown in the figure. In this slot is fitted an adjustable pin and to this is attached a connecting rod. The other end of the connecting rod is attached to the lower end of the rocker arm of the pawl mechanism.

The rocker arm swings about the screw C, and at its upper end carries a spring loaded pawl, as shown.

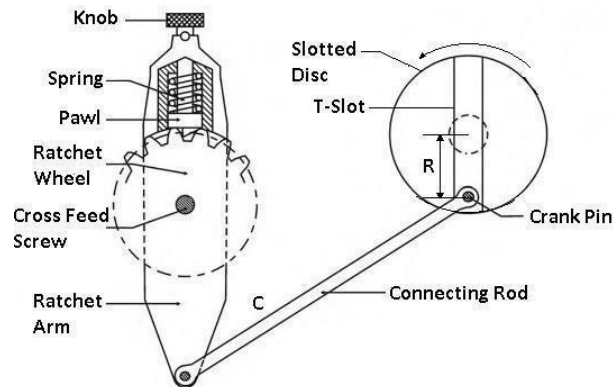

Working

Note, that the lower end of the pawl is swelled on one side.

This arrangement helps the power feed to operate in either direction, but the same should be set to operate during the return stroke only.

If otherwise, the mechanism will be subjected to a severe stress. In some latest types of shapers, can driven feed mechanisms are provided which are more efficient and provide a wider range of feed.

Variation in the feed can be provided by varying the distance R between the disc centre and the centre of the adjustable pin.

Larger the said distance greater will be the feed and vice versa. The amount of feed to be given depends upon the type of finish required on the job.

For rough machining, heavier cuts are employed, and thus, a coarse feed is needed. Against this, a finer feed is employed in finishing operations.

The slotted disc at its back carries a spur gear which is driven by the bull gear. As the disc rotates through this gear the adjustable pin, being eccentric with the disc centre.

This causes the connecting rod to reciprocate. This, in turn, makes the rocker arm to swing about the screw C to move the pawl over one or more teeth.

Thus transmit an intermittent motion to the cross feed screw which moves the table.

Specification of shaper:-

1. Maximum length of stroke(175-900mm)
2. Maximum horizontal travel of table
3. Maximum vertical travel of table
4. Maximum distance from table to ram
5. Tool box, vertical adjustment
6. Length and width of the table
7. Numbers and range speeds available
8. Numbers and range feeds available
9. Horse power and speed of driving motor
10. Weight of the machine and floor space required

Tool Head:



The tool head holds the cutting tool firmly and provides both vertical and angular movement to the tool with the help of a down feed screw handle.

The head allows the tool to have an automatic relief during the return stroke.

The vertical slide of a tool head consists of a swivel base which is graduated in degrees. So, the vertical slide can set at any angle with the work surface.

The amount of feed or depth of cut may be adjusted by a micrometer dial on top of the down feed screw.

A tool head again consists of:

- Apron
- Clapper box and clapper block

Apron consisting of clapper box and tool post is clamped on the vertical slide by the screw.

The **apron** Can be swiveled upon the apron swivel pin towards left or right.

The **clapper box** houses the **clapper block** by means of a hinge pin.

The **tool post** is mounted on the **clapper block**.

During forwarding cutting stroke the clapper block keeps the rigid support to the tool by fitting securely into clapper box and while returning stroke the tools slide over the work by lifting, the block out of clapper boxes shown in the above figure

.

PLANNER MACHINE

Difference between a shaper and a planner

- **In a planer**, the work which is supported on the table reciprocates over the stationary cutting tool. And the feed is supplied by the lateral movement of the tool.
- **In a shaper**, the tool which is mounted upon the ram reciprocates. And the feed is given by the crosswise movement of the table.

SHAPER.

PLANNER

Suitable for machining small and medium-size work, one or few at a time.

Not suitable for machining small and medium-size work, one or few at a time.

Usually, only one tool is used on a shaper.

Multiple tooling permits machining of more than one surface at a time.

Cutting and return speeds vary throughout the strokes.

Cutting and return speeds are uniform throughout the strokes.

Work setting requires less skill and less time.

Work setting requires more skill and more time.

Tools used are lighter and smaller.

Tools used are heavier, stronger and larger.

. It requires less floor space.

It required large floor space.

Parts of Planer Machine

Following are the important parts of the planer machine:

- Bed
- Table or Platen

- Housing or Column
- Cross rail
- Tool head
- Driving and Feed Mechanism

Bed

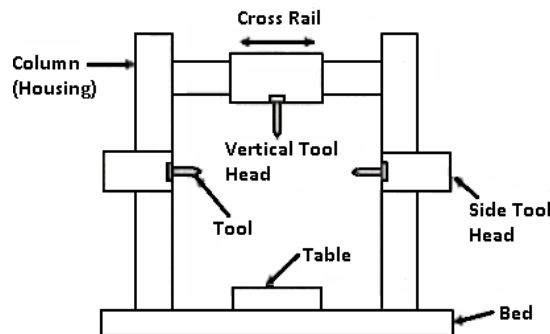

PLANER MACHINE

- The bed of a planer is a box-like casting having cross ribs. It is very large in size and heavy in weight and it supports the column and all other moving parts of the machine.
- The bed is made slightly longer than twice the length of the table so that the full length of the table may be moved on it.
- It is provided with precision ways over the entire length on its top surface and the table slides on it.
- In a standard machine, two V-type of guideways are provided.
- Three or more guideways may be provided on a very large wide machine for supporting the table.
- Some of these guideways may be the flat type to lend support to the table.
- The guideways should be horizontal, true and parallel to each other.
- The ways are properly lubricated and in modern machines oil under pressure is pumped into the different parts of the guideways to ensure a continuous and adequate supply of lubricants.
- The hollow space within the box-like the structure of the bed houses the driving mechanism for the table.

Table

- The table supports the work and reciprocates along with the ways of the bed.
- The planer table is a heavy rectangular casting and is made of good quality cast-iron.
- The top face of the planer table is accurately finished in order to locate the work correctly.
- T-slots are provided on the entire length of the table so that the work and work holding devices may be bolted upon it.
- Accurate holes are drilled on the top surface of the planer table at regular intervals for supporting the poppets and stop pins.
- At each end of the table, a hollow space is left which acts as a trough for collecting chips. Long works can also rest upon the troughs.

- A groove is cut on the side of the table for clamping planer reversing dogs at different positions.
- In a standard planer, the table is made up of one single casting but in a divided table planer there are two separate tables mounted upon the bedways.

Housing

- The housings also called columns or uprights are rigid box-like vertical structures placed on each side of the bed and are fastened to the sides of the bed.
- They are heavily ribbed to take up severe forces due to cutting.
- The front face of each housing is accurately machined to provide precision ways on which the cross rail may be made to slide up and down for accommodating different heights of work.
- Two side-toolheads also slide upon it. The housing encloses the Crossrail elevating screw, vertical and crossfeed screws for tool heads, counterbalancing weight for the Crossrail, etc. These screws operated either by hand or power.

Cross rail

- The Crossrail is a rigid box-like casting connecting the two housings. This construction ensures the rigidity of the machine.
- The Crossrail may be raised or lowered on the face of the housing and can be clamped at any desired position by manual, hydraulic or electrical clamping devices.
- The Crossrail when clamped should remain absolutely parallel to the top surface of the table, i.e. it must be horizontal irrespective of its position.
- This is necessary to generate a flat horizontal surface on a workpiece because the tool follows the path on the Crossrail during crossfeed.
- The two elevating screws in the two housing are rotated by an equal amount to keep the Crossrail horizontal in any position.
- The front face of the cross rail is accurately machined to provide a guide surface for the tool head saddle.
- Usually, two toolheads are mounted upon the Crossrail which are called railhead.
- The Crossrail has screws for vertical and crossfeed of the tool heads and a screw forelevating the rail. These screws rotated either by hand or by power.

Table drive mechanism

Open and Cross belt Drive Mechanism:

This mechanism is used in a small size planer.

The principle operation of the open and cross belt drive is illustrated in the figure.

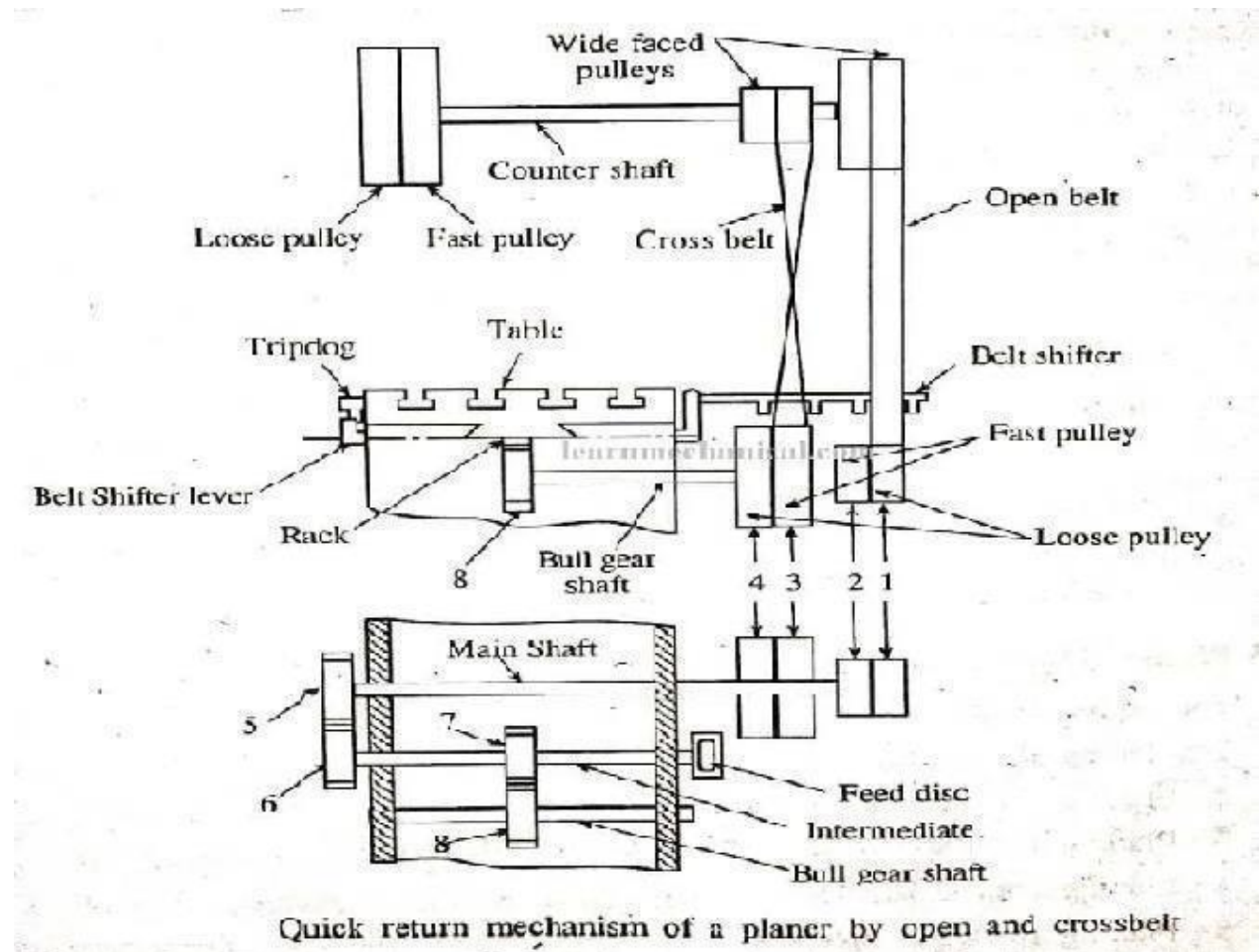

The countershaft mounted on housing is driven by the motor on which fast and lose pulleys are fixed. By shifting the belt from loose to fast pulley the machine is started or by shifting the belt from fast to loose pulley the machine can be stopped. The small diameter pulley drives the crossed belt and large diameter pulley drivers the open belt.

The crossed belt further connects to the larger diameter pulleys 3(loose pulley)and 4(fast pulley) which are keyed to the main shaft of the table and the open belt connects the smaller diameter pulleys 1 (loose pulley) and 2(fast pulley) on the main shaft.

When the counter shaft rotates the motion will be transmitted to the main shaft of the table through fast pulleys of the cross or open belt and no motion will be transmitted when the belt is on loose pulley. The motion of the main shaft is transmitted through gear 5, 6 and 7 to the bull gear 8. The bull gear meshes with a rack at the underside of the table, which converts the rotary motion to linear motion thereby table starts reciprocating.

The crossed belt is used for driving the table during a cutting stroke, which gives greater power and less speed by having the greater power and the speed is reduced as the belt connects smaller pulley on the countershaft to the larger pulley (3) on the main shaft of the table.

At the end of the forward cutting stroke. The trip dog mounted on the side of the planer table operates a belt shifter through a lever arrangement, thereby shifting the crossed belt from fast pulley(1) to loose pulley(2).

The motion is now transmitted from the larger pulley on the countershaft to the fast pulley on the main shaft and no motion is transmitted by crossed belt to the main shaft.

When the shaft receives the motion from an open belt, the direction of rotation of the shaft reversed and table starts moving to perform return stroke with a high speed as the open belt connects the larger diameter pulley on the countershaft with the smaller diameter pulley on the main shaft and thus obtaining the quick return motion.

At the end of the return stroke, second trip dog will hit against the belt shifter lever causing the cross belt to shift from loose pulley (4) lever causing the cross belt to shift from loose pulley (4) to fast pulley (3) and open belt to shift from fast pulley (2) to loose pulley (1) to repeat the cycle of cutting stroke and return stroke. The length and position of the stroke may be adjusted by shifting the dog position.

CLAMPING OF JOB:

There are three important points to be hosted while clamping the job on the planer table.

The work should be connected rigidly to the table so that it may not be shifted out of its position while cutting progresses.

Proper clamping should be done all round the job.

The job should be so held that the surface planed should remain in proper position with other surface.

The job may be located on the planning machine table by the following methods.

By standard clamping devices.

By special fixtures.

The standard clamping devices are t-bolts, stops, planer jacks, heavy duty vises, angle plates & planner centres etc.

Work Holding devices used in Planner

- a) Heavy duty vises
- b) T-bolts and Clamps
- c) Step blocks,T-bolts and Clamps
- d) Poppets or stop pins and dogs

e) Angle plates

f) Planer centers

g) Planer Jacks

h) V- blocks

i) Stops .

Milling Machine

Milling is the machining process in which the removal of metal takes place due to the cutting action of a rotating milling cutter.

In a **milling machine**, the cutter is rotating due to this workpiece is fed against it. This can hold more than one tool at a time. The cutter rotates at a high speed and because of the many cutting edges, it removes metal at a very fast rate.

Type of Milling Machines

Milling machines can be classified into different categories depending upon their construction, specification and operations. The choice of any particular machine is primarily determined by nature of the work to be done, its size, geometry and operations to be performed.

The broader classification has three categories and each category has its sub-classifications given below:

Column and Knee Type Milling Machine

- (a) Head milling machine
- (b) Plain milling machine
- (c) Universal milling machine
- (d) Omniversal milling machine
- (e) Vertical milling machine

Fixed Bed Type Milling Machine

- (a) Simplex milling
- (b) Duplex milling
- (c) Triplex milling

Special Type Milling Machine

- (a) Rotary table milling
- (b) Drum milling
- (c) Planetary milling
- (d) Tracer controlled milling

Column and Knee Type Milling Machine

This milling machine consists of a base having different control mechanisms housed there in. The base consists of a vertical column at one of its end. There is one more base above the main base and attached to the column that serves as worktable equipped with different attachments to hold the workpiece. This base having worktable is identified as “knee” of the milling machine. At the top of the column and knee type milling machines are classified according to the various methods of supplying power to the table, different movements of the table and different axis of rotation of the main spindle. These are described in brief as below.

Head Milling Machine

In case of head milling machine feed motion is given by hand and movements of the machine are provided by motor. This is simple and light duty milling machine meant for basic operations.

Plain Milling Machine

Plain milling machine is similar to hand milling machine but feed movement can be powered controlled in addition to manual control.

Universal Milling Machine

A universal milling machine is named so as it is used to do a large variety of operations. The distinguishing feature of this milling machine is its table which is mounted on a circular swiveling base which has degree graduations. The table can be swiveled to any angle upto 45° on either side of normal position. Helical milling operation is possible on universal milling machine as its table can be fed to cutter at an angle. Provision of large number of auxiliaries like dividing head, vertical milling attachments, rotary table, etc. make it suitable for wide variety of operations.

Omniversal Milling Machine

Omniversal milling machine is like a universal milling machine with additional feature that its table can be tilted in a vertical plane by providing a swivel arrangement at the knee. This enables it to make taper spiral grooves in reamers, bevel gears, etc.

Vertical Milling Machine

Position of spindle is kept vertical or perpendicular to the worktable in case of vertical milling machine.

Parts of Milling Machine

Following are the **parts of milling machine**:

1. Base
2. Column
3. Saddle
4. Table

5. Overhanging arm
6. Front brace
7. Spindle
8. Arbor

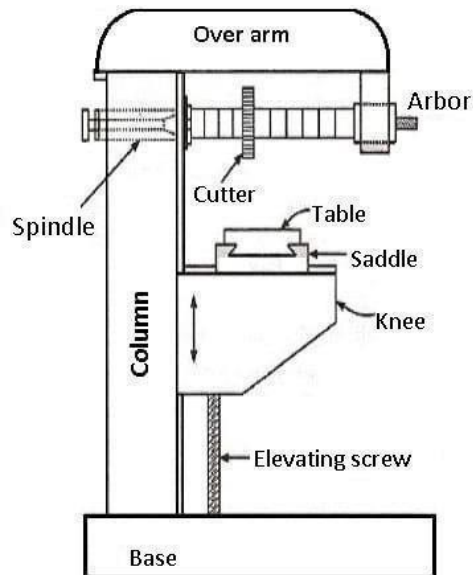

Base

- The base of the machine is grey iron casting and serves as a foundation member for all other parts which rests on it.
- The base carries the column at its one end. In some other machines, the base is hollow and works as a reservoir for cutting fluid.

Column

- The column is the main supporting frame mounted on the base.
- It is box-shaped and houses all the driving mechanism for the spindle and feed table.
- The front vertical face of the column is precisely machined and is equipped with dovetail guideways for supporting the knee.
- The top of the column is finished to hold an overarm that extends beyond the front of the machine.

Knee

- The knee is a fixed grey iron casting that slides up and down on the vertical ways of the column face.
- The adjustment of height is affected by an elevating screw mounted on the base that also supports the knee.
- The knee houses the feed mechanism of the table and controls to operate it.
- The top face of the knee forms a slideway for the saddle that gives cross travel to the table.

Saddle

- On the top of the knee is placed the saddle, which slides on guideways set exactly at 90 degrees to the column face.
- A crossfeed screw near the top of the knee engages a nut on the bottom of the saddle to move it horizontally, by hand or power, to apply cross-feed.
- The top of the saddle is precisely machined to provide guideways for the table.

Table

- It rests on guideways on the saddle and travels longitudinally.
- The top of the table is finished accurately and T-slots are provided for clamping the work and other fixtures.
- A lead-screw is provided under the table that engages with a nut on the saddle, it helps to move the table horizontally by hand or power..
- In universal machines, the table may also be swivelled horizontally. For this purpose, the table is mounted on a circular base, which in its turn is mounted on the saddle.
- The circular base is graduated in degrees.

Overhanging arm

- Overhanging arm act as a support for the arbor.
- It is mounted on the top of the column extends outwards the column face and works as bearing support for the other end of the arbor.
- The Overhanging arm is adjustable so that the bearing support may be provided nearest to the cutter.
- More than one bearing support can be provided for the arbor.

Spindle

- The spindle of the machine is located in the upper part of the column and receives power from the motor through belts, gears, and clutches and transmit it to the arbor.
- The front end of the spindle just projects from the column face and is provided with a tapered hole into which various cutting tools and arbor may be inserted.
- The accuracy in metal machining by the cutter depends on the strength, accuracy and rigidity of the spindle.

Arbor

- Arbor is an extension of the machine spindle on which milling cutters are securely mounted and rotated.
- These are made with taper shanks for proper alignment with the machine spindles having taper holes at their nose.

- The arbor may be supported at the farthest end from the overhanging arm or maybe of cantilever type which is called stub arbor.

Working Principle of Milling Machine

The working principle of the milling machine, applied in the metal removing operation on a milling machine. The work is rigidly clamped on the table of the machine and revolving multi teeth cutter mounted either on a spindle.

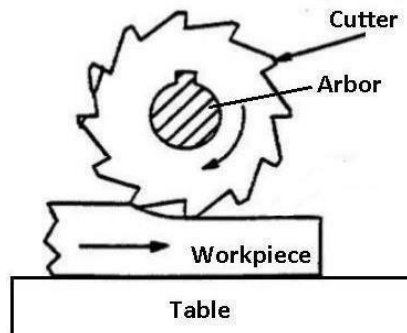

The cutter revolves at a normal speed and the work fed slowly past the cutter. The work can be fed in a longitudinal, vertical or cross direction. As the work progress further, the cutter teeth remove the metal from the work surface to produce the desired shape.

Milling Machine Operations

Following are the different types of operations performed on milling machine:

1. Plain Milling Operation
2. Face Milling Operation
3. Side Milling Operation
4. Straddle Milling Operation
5. Angular Milling Operation
6. Gang Milling Operation
7. Form Milling Operation
8. Profile Milling Operation
9. End Milling Operation
10. Saw Milling Operation
11. Milling Keyways, Grooves, and Slot
12. Gear Milling
13. Helical Milling
14. Cam Milling
15. Thread Milling

Working Principle of Milling Machine

The working principle of the milling machine, applied in the metal removing operation on a milling machine. The work is rigidly clamped on the table of the machine and revolving multi teeth cutter mounted either on a spindle.

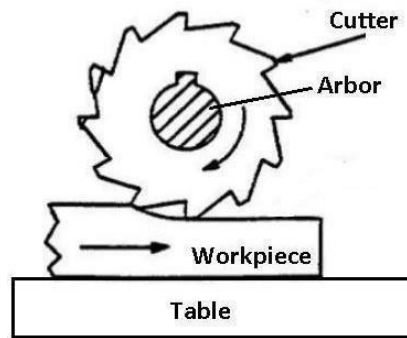

The cutter revolves at a normal speed and the work fed slowly past the cutter. The work can be fed in a longitudinal, vertical or cross direction. As the work progress further, the cutter teeth remove the metal from the work surface to produce the desired shape.

Construction And Working of Universal Dividing Head

Parts Used in Indexing Mechanism:-

Indexing Plate – Indexing plate is a circular plate and it has equally spaced holes. There are minimum 6 holes in an indexing plate. This indexing plate is connected to a crank which is connected to a handle. This indexing plate is stationary in Simple Indexing Mechanism and can move in Differential Indexing Mechanism.

Crank – This crank has a handle which is rotated manually and give the initial rotation to the worm shaft and worm which transferred to the worm wheel.

Crank Pin – Crank Pin is used to lock the rotation of the crank. Crank pin is inserted into the whole of indexing plate which is fixed and does not rotate and hence the rotation of crank is locked.

Worm Shaft – This shaft is connected with the crank and rotates with it. It connects the crank to the worm.

Worm – Worm is connected to the crank by worm shaft. This worm is like a threaded screw. It is a single-threaded worm. When the crank is rotated using handle this worm also rotates due to rotation of worm shaft and a single tooth in worm wheel which is connected to the worm passes through the worm.

Worm Wheel (W.W) – The worm wheel contains teeth like gears. When all the teeth of worm wheel passes through the worm. The worm wheel completes one rotation.

Spindle :- Spindle is connected with the worm wheel and rotates as the worm wheel rotates. When all the teeth of worm wheel passes through the worm, this worm wheel completes one rotation and the spindle connected to the worm wheel also completes one rotation. This spindle is connected to a plate known as face plate.

Face Plate – This face plate is connected to the spindle and rotates as the spindle rotates.

This face plate is connected to the workpiece and this workpiece also rotates with this face plate.

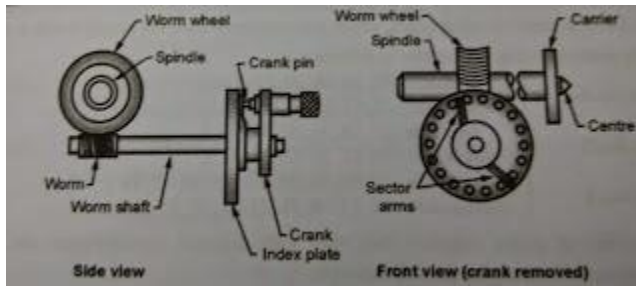

This worm carries a crank at its outer end. The index pin works inside the spring-loaded plunger, which can slide radially along a slot provided in the crank.

This plunger can slide, adjust the pin position along a desired hole circle on the index plate.

The index plate is mounted on the same spindle as the crank, but on a sleeve, hence the crank and worm spindle can move independently on the index plate.

To set a definite distance along the desired hole circle, sector arms are used. Sector arms are of a detachable type and can be set at the desired angles with one another. The index plates are available in a set of two or three, with a number of hole circles generally on both sides.

Procedure of indexing

1. Direct Indexing:

In this case, the dividing head has an index plate, fitted directly on the spindle. The intermediate use of worm and worm-wheel is avoided. The index plate has 24 holes and the periphery of job can be divided into 2, 3, 4, 6, 8 and 12 equal parts directly. This type indexing is most commonly used for indexing fixture.

2. Simple or Plain Indexing:

In this case, different index plates with varying number of holes are used to increase the range of indexing. The index is fixed in position by a pin called lockpin. The spindle is then rotated by rotating the handle which is keyed to the worm-shaft as shown in Fig.

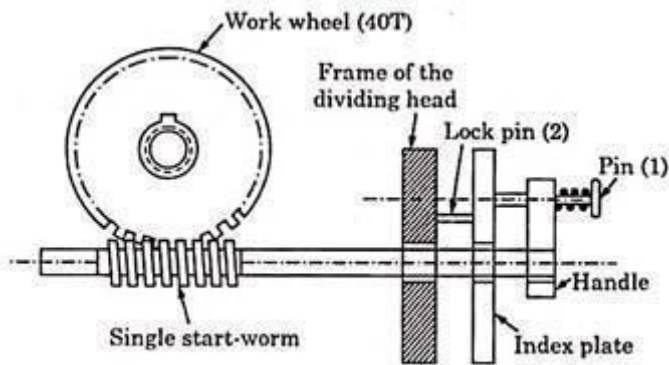

Fig. 16.61

The following relation is used for simple indexing: $T = 40/N$, where T gives the number of turns or parts of a turn through which the index crank must be rotated to obtain the required number of divisions (N) on the job periphery.

Let us take an example of a gear blank on which 64 teeth are to be cut.

$$\text{Here } T = \frac{40}{N} = \frac{40}{24} = 1 \frac{16}{24} \text{ or } 1 \frac{2}{3}$$

i.e., the worm is to be rotated by the handle through one complete rotation and two-third of the number of holes of any circle.

3. Compound Indexing:

The principle of operation of compound indexing is the same as that of simple indexing, but the only difference is that compound indexing uses two different circles of one plate and hence also sometimes referred to as hit and trial method.

The principle of compound indexing is to obtain the required division in two stages:

- (i) By rotating the crank or handle in usual way keeping the index plate fixed.
- (ii) By releasing the back pin and then rotating the index plate with the handle.

For example, if a 27 teeth gear is to be cut, then $T = 40/27$ i.e., the rotation required for one tooth spacing is $40/27$ which may be written as $2/3 + 22/27$ or $12/18 + 22/27$.

So for each tooth, the worm will be rotated by 12 holes of 18 hole circle with the help of the crank and then the index plate is rotated by 22 holes of the 27 hole circle.

Slotter Machine

The **slotter machine** falls under the category of the reciprocating type of machine tool similar to a shaper or a planner. It operates almost on the same principle

The major difference between a slotter machine and a shaper machine is that in a slotter the ram holding the tool reciprocates in the vertical axis. whereas in a shaper the ram holding the tool reciprocates in a horizontal axis. A vertical shaper and slotter machines are almost similar to each other as regards their construction, operation, and use.

The only difference being, in the case of a **vertical shaper**, the ram holding the tool may also reciprocate at an angle to the horizontal table in addition to the vertical stroke. The ram can be swivelled not more than 5° to the vertical.

.

Types of Slotter Machine

There are mainly two **types of slotter machine**.

1. Puncher slotter.
2. Precision slotter.

1. Puncher Slotter

The **puncher slotter** machine is a heavy, rigid machine designed for removal of a large amount of metal from large forgings or castings. The length of stroke of a puncher slotter is sufficiently large. It may be as long as 1800 to 2000mm.

The puncher slotter ram is usually driven by a spiral pinion meshing with the rack teeth cut on the underside of the ram. The pinion is driven by a variable speed reversible electric motor. The feed is also controlled by electrical gears.

2. Precision Slotter

The precision slotter machine is a lighter machine and is operated at high speeds. The machine is designed to take light cuts giving the accurate finish.

Using special jigs, the machine can handle a number of works on a production basis. The precision slotter machines are also used for general purpose work and are usually fitted with Whitworth quick return mechanism.

Parts of Slotter Machine

The different parts of a slotter machine are,

1. Base.
2. Column.

3. Saddle.
4. Crossslide.
5. Rotating table.
6. Ram and tool head assembly.
7. Ram drive mechanism.
8. Feed mechanism.

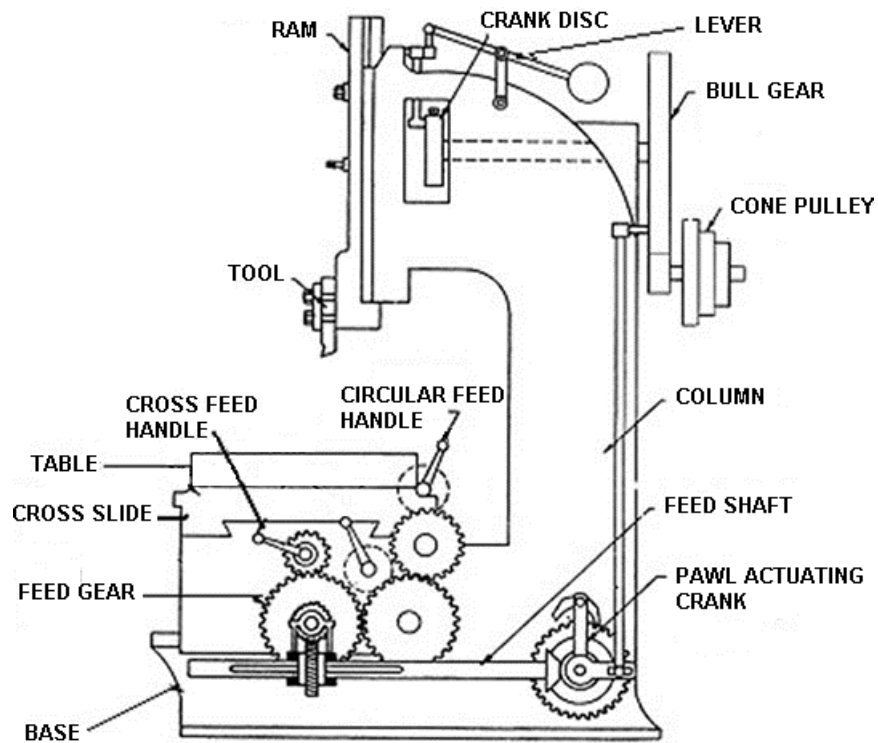

SLOTTER MACHINE

1. Base or Bed

- The base is rigidly built to take up all the cutting forces and the entire load of the machine.
- The top of the bed is accurately finished to provide guideways on which the saddle is mounted.
- The guideways are perpendicular to the column face.

2. Column

- The column is the vertical member which is cast integrally with the base and houses driving mechanism of the ram and feeding mechanism.
- The front vertical face of the column is accurately finished for providing ways in which the ram reciprocates.

3. Saddle

- The saddle is mounted upon the guideways and may be moved toward or away from the column either power or manual control to supply longitudinal feed to the work.
- The top face of the saddle is accurately finished to provide guideways for the cross-slide. These guideways are perpendicular to the guideways on the base.

4. Cross-slide

- The cross-slide is mounted upon the guideways of the saddle and maybe moved parallel to the face of the column.
- The movement of the slide may be controlled either by hand or power to supply crossfeed.

5. Rotary Table

- The rotary table is a circular table which is mounted on the top of the cross-slide.
- The table may be rotated by rotating a worm which meshes with a worm gear connected to the underside of the table.
- The rotation of the table may be effected either by hand or power. In some
- In some machines, the table is graduated in degrees that enable the table to be rotated for indexing or dividing the periphery of a job in the equal number of parts.
- T-slots are cut on the top face of the table for holding the work by different clamping devices. The rotary table enables a circular or contoured surface to be generated on the workpiece.

6. Ram and Toolhead Assembly

- The ram is the reciprocating member of the machine mounted on the guideways of the column. It supports the tool at its bottom end on a tool head.
- A slot is cut on the body of the ram for changing the position of the stroke.
- In some machines, special type for tool holders is provided to relieve the tool during its return stroke.

7. Ram Drive Mechanism

A slotter removes metal during downward cutting stroke only whereas during upward return stroke no metal is removed. To reduce the idle return time quick return mechanism is incorporated in the machine. The usual types of ram drive mechanism are,

1. Whitworth quick return mechanism.
2. Variable speed reversible motor drive mechanism.
3. Hydraulic drive mechanism.

Whitworth Quick Return Mechanism

A simple Whitworth quick return mechanism as shown in fig. The bull gear is mounted on a fixed hub at the rear end of the machine and it is rotated by a driving pinion from the motor. The driving plate is connected to the main shaft through the fixed hub. The main shaft is placed eccentrically with respect to the bull gear centre.

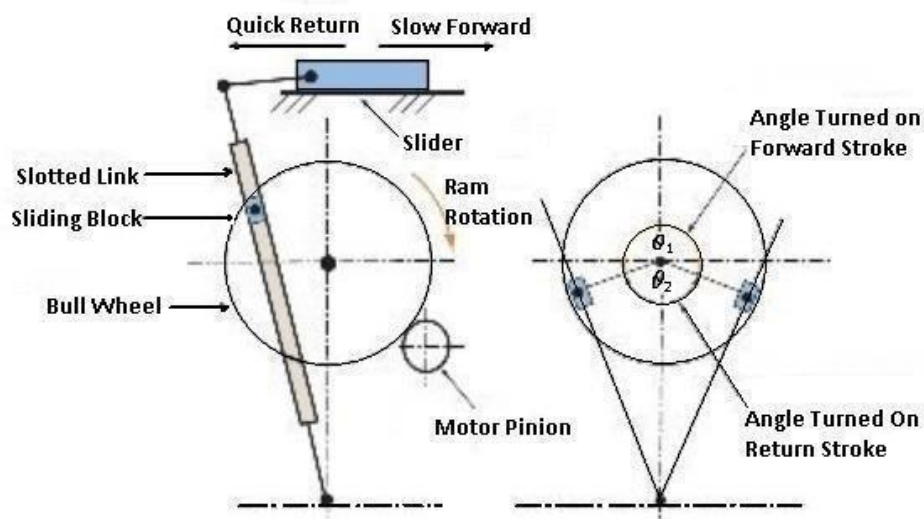

The bull gear holds the crankpin with sliding block and slides in a driving plate. So that when the bull gear rotates, imparts rotary motion to the driving plate and shaft causing the disc to rotate at the end of the main shaft.

The disc is connected to the lower end of the connecting rod eccentrically by means of a pin in a radial T-slots on the face of the disc, which converts the rotary motion of the disc into reciprocating motion of the ram connected to the top end of the connecting rod.

Working of Slotter Machine

The working of the slotter machine is the same as that of shaper machine but the difference is that shaper cuts the metal horizontally and slotter cuts the metal vertically. First, the workpiece that is to be slotted is mounted on the table. The table has T-slots that help the workpiece to hold firmly on it.

After clamping the workpiece on the table a cutting tool is inserted into the tool head for cutting the metal. Here the tool is made of HSS (High-speed steel).

And then the machine is ON that allows the ram to move upward and downward in a vertical direction.

As the ram moves downward called a downward stroke, it cuts the metal from the workpiece and then returns quickly (called as return stroke) without cutting the metal. So we can say that the slotter machine cuts the metal in downstroke and remains idle i.e. does not cut any metal in return stroke.

Feed in slotter can be worked automatically or manually. There is a mechanism inside it that allows the movement of the table, cross slide according to the ram movement.

automatically. The movements of each part are interlinked with each other

GRINDING

SIGNIFICANCE OF GRINDING OPERATIONS

Grinding is a metal cutting operation like any other process of machining removing metal in comparatively smaller volume. The cutting tool used is an abrasive wheel having many numbers of cutting edges. The machine on which grinding the operation is performed is called a grinding machine. Grinding is done to obtain very high dimensional accuracy and better appearance.

Types of grinding machines

According to the accuracy of the work to be done on a grinding machine, they are classified as

1. Rough grinding machines
2. Precision grinding machines

MANUFACTURING OF GRINDING WHEEL

Abrasives

Abrasives are used for grinding and polishing operations. It should have uniform physical properties of hardness, toughness and resistance to fracture. Abrasive may be classified into two principal groups.

1. Natural abrasives
2. Artificial abrasives

Natural abrasives

The natural abrasives are obtained from the Earth's crust. They include sandstone, emery, corundum and diamond. Sandstone is used as abrasive to grind softer materials only.

Emery is natural alumina. It contains aluminum oxide and iron oxide. Corundum is also a natural aluminum oxide. It contains greater percentage of aluminum oxide than emery. Both emery and corundum have a greater hardness and abrasive action than sandstone.

Diamond is the hardest available natural abrasive. It is used in making grinding wheels to grind cemented carbide tools.

Artificial abrasives

Artificial abrasives are of two types.

1. Silicon carbide abrasives
2. Aluminum oxide abrasives

Silicon carbide

Silicon carbide is manufactured from 56 parts of silica, 34 parts of powdered coke, 2 parts of salt and 12 parts of sawdust . There are two types of silicon carbide abrasives - green grit and black grit.

Silicon carbide is next to diamond in the order of hardness. But it is not tough enough as aluminium oxide. It is used for grinding materials of low tensile strength such as cemented carbides, ceramic materials, grey brass, bronze, copper, aluminium, etc.

It is denoted by the letter 'S'.

Aluminium oxide

Aluminium oxide is manufactured by heating mineral bauxite, silica, iron oxide, titanium oxide, etc., mixed with ground coke and iron borings in arc type electric furnace. It is better adapted to grinding materials of high tensile strength such as most steels, carbon steels, high speed steels, and tough bronzes. This is denoted by the letter 'A'.

Types of bonds

A bond is an adhesive substance that is employed to hold abrasive grains together in the form of grinding wheels. There are several types of bonds. Different grinding wheels are manufactured by mixing hard abrasives with suitable bonds. The table containing the types of wheels manufactured using different types of bonds and their

Type of bond	Symbol	Grinding wheel
1. Vitrified	V	Vitrified wheel
2. Silicate	S	Silicate wheel
3. Shellac	E	Elastic wheel
4. Resinoid	B	Resinoid wheel
5. Rubber	R	Vulcanised wheel
6. Oxychloride	O	Oxychloride wheel

Grain size, Grade and Structure

Grain size (Grit)

The grinding wheel is made up of thousands of abrasive grains. The grain size or grit number indicates the size of the abrasive grains used in making a wheel, or the size of the cutting teeth. Grain size is denoted by a number indicating the number of meshes per linear inch of the screen through which the grains pass when they are graded. There are four different groups of the grain size namely coarse, medium, fine and very fine. If the grit number is large, the size of the abrasive is fine and a small grit .

Coarse	:	10, 12, 14, 16, 20, 24
Medium	:	30, 36, 46, 54, 60
Fine	:	80, 100, 120, 150, 180
Very fine	:	220, 240, 280, 320, 400, 500, 600

Grade

The grade of a grinding wheel refers to the hardness with which the wheel holds the abrasive grains in place. It does not refer to the hardness of the abrasive grains. The grade is indicated by a letter of the English alphabet. The term 'soft' or 'hard' refers to the resistance a bond offers to disruption of the abrasives. A wheel from which the abrasive grains can easily be dislodged is called soft whereas the one, which holds the grains more securely, is called hard. The grade of the bond can be classified in three categories.

Soft	:	A B C D E F G H
Medium	:	I J K L M N O P
Hard	:	Q R S T U V W X Y Z

Structure

The relative spacing occupied by the abrasives and the bond is referred to as structure. It is denoted by the number and size of void spaces between grains. It may be 'dense' or 'open'. Open structured wheels are used to grind soft and ductile materials. Dense wheels are useful in grinding brittle materials.

Dense	:	1 2 3 4 5 6 7 8
Open	:	9 10 11 12 13 14 15 or higher

SPECIFICATION OF GRINDING WHEEL

The Indian standard marking system for grinding wheels has been prepared with a

view of establishing a uniform system of marking of grinding wheels to designate their various characteristics.

Prefix	Manufacturer's abrasive type symbol
First element (letter)	Type of abrasive
Second element (number)	Size of abrasive
Third element (letter)	Grade of bond
Fourth element (number)	Structure of the grinding wheel
Fifth element (letter)	Type of bond
Suffix	Manufacturer's symbol

Working principle of surface grinding machine

It uses a rotating abrasive wheel to remove the material from the surface of the workpiece to create a flat surface with a high surface finish.

The grinding wheel revolves on a spindle and the workpiece is mounted on a reciprocating table.

The reciprocating table moves in a forward or backward direction and the workpiece is adjusted w.r.t. the grinding wheel position.

When the power supply is given and suitable speed is provided to the grinding wheel, the grinding wheel rotates on the surface of the workpiece to remove the material from the surface of the workpiece till high accuracy is obtained.

The Aluminum oxide, diamond, silicon carbide, and cubic boron nitride (CBN) are four commonly used abrasive materials for the surface of the grinding wheels.

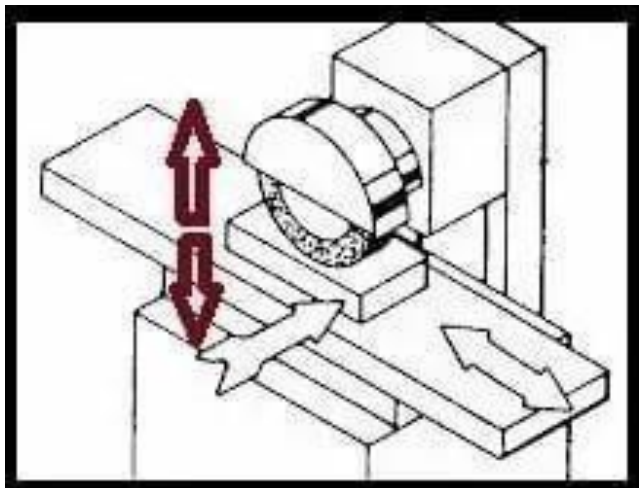

Working Principle of Cylindrical Grinding:

.

In this, the operation is carried out on a cylindrical grinding machine which is made in two varieties "plain" and the "universal" type. The fundamental design is the same in both cases, but the universal machine can be adapted for internal grinding operation as well.

In cylindrical grinding machine operation, the work is mounted between two centres and rotates. A grinding wheel is mounted on a spindle and revolves at a higher speed than the work. The depth of cut is very small, about 0.015 mm.

The work centres are mounted on a table which can transverse at various feeds so that the entire length of the work passes to and fro in front of the wheel.

When the entire work has passed in front of the wheel, the wheel advances forward by another 0.015mm at the end of the transverse and so the cycle of machining goes on until the desired diameter of the workpiece is reached. The result is a long cylinder of the perfectly circular profile with a very fine surface finish.

Working Principle of Centerless grinding:

Centerless grinding describes a technique that holds the workpiece in the center between two grinding wheels, which rotate in the same direction (usually clockwise). The left side grinding wheel is held in position as it rotates.

The direction of force applied to the workpiece by the left side grinding wheel is downwards towards the platform that holds the workpiece in place.

The secondary grinding wheel to the right is called the regulating wheel. It has the flexibility to move in response to the pressures applied to the workpiece between the two grinding wheels.

The regulating wheel keeps the workpiece in place and turns it for grinding by the grinding wheel.

1. Answer All the Questions.

(2x10)

- (a) State the composition of HSS Tool.
- (b) Define depth of cut.
- (c) List the operations carried out in a Lathe.
- (d) What are the types of grinders?
- (e) Define drilling & boring.
- (f) What is super finishing?
- (g) What is the function of Ram?
- (h) Define Abrasive.
- (i) Define grinding.
- (j) What is broaching?

2. Answer Any Six Questions.

(5x6)

- (a) What are the characteristics of tool material?
- (b) Differentiate between Capstan & Turret Lathe.
- (c) Explain working of slotter.
- (d) Describe the properties of coolant & lubricant.
- (e) Explain the specification of grinding wheel.
- (f) With neat block diagram show different components of shaper m/c.
- (g) Explain cutting action of a Reamer.

3. Draw three views of a single point cutting tool & explain the cutting Angles. (10)

4. Explain the working of an Universal dividing head. (10)

5. Explain the Quick Return mechanism of a shaper machine. (10)

6. Describe the composition, properties & use of various cutting tool material. (10)

7. With neat sketch explain the clamping device of a Planner. (10)

ANSWER ANY FIVE QUESTION INCLUDING Q. NO 1 & 2.

1. ANSWER ALL THE QUESTIONS.

- (2x10)
- Define Abrasive.
 - What is the function of ram in sloter?
 - Name the different type of Milling Machine.
 - What are the composition of Carbon steel?
 - Write four main parts of Lathe.
 - Define the multiple tool holder.
 - Why coolants are used?
 - Write four clamping device of a planer m/c.
 - Differentiate between orthogonal & oblique cutting.
 - Define Indexing.

2. ANSWER ANY SIX QUESTION.

- (5x6)
- Explain the working of Radial drilling machine.
 - Explain the method of Taper-Turning operation.
 - Difference between upmilling & Down milling.
 - Explain cutting Action of a hacksaw blade.
 - Explain the Automatic table Feed mechanism of a shaper m/c.
 - Explain the working of Centreless grinder.
 - Draw the diagram of an Universal milling machine & show it's all part.
3. Show & Explain different parts of Capstan Lathe. (10)
4. Explain single point cutting tool Nomenclature. (10)
5. Explain the Quick Return mechanism of a shaper. (10)
6. Explain the manufacturing process of grinding wheel. (10)
7. How we make a hexagonal Nut & bolt? Explain in detail. (10)

IV SEM - MECH. ENGG.

TH-2: MANUFACTURING TECHNOLOGY

FULL MARK-80

TIME-3 HOURS

ANSWER ANY FIVE QUESTION INCLUDING Q. NO 1 & 2

1. ANSWER ALL THE QUESTIONS. (2x10)
- Name various cutting tool material.
 - State the operations which may performed on a Lathe.
 - Why chucks are used?
 - Name different types of drilling machine?
 - Define coolant.
 - What is centreless grinding?
 - Define Depth of cut.
 - State the specification of shaper.
 - What do you mean by surface finishing?
 - Necessity of broaching.
2. ANSWER ANY SIX QUESTION. (5x6)
- List various hand tools & discuss their cutting action.
 - Explain different methods of taper turning.
 - Draw the sketch of capstan & turret lathe with Nomenclature.
 - Describe the main parts of a slotting machine (Any three).
 - Explain the specification of grinding wheels.
 - Draw a simple dividing head & explain it's working.
 - State the properties & uses of any one cutting tool material.
3. Explain with a neat sketch the geometry of a Turning tool. (10)
4. Describe the desirable properties of Coolant & Lubricant. (10)
5. With a neat sketch explain Quick return mechanism of a shaper. (10)
6. Explain cutting Action of a Reamer & chisel. (10)
7. Difference between Shaper & Planner machine. (10).

Drilling Machine

(i) Drilling is an operation through which holes are produce in solid metals.

(ii) The process of making hole is done by the help of a tool which is known as drill tool.

(iii) In drilling operation it is not possible to produce a perfectly true hole with accurate dimensions and surface finish. So, it can be considered as roughing operations.

Q-1 classify drilling machines.

Ans classification of drilling machine:-

- (1) Portable drilling m/c
- (2) Sensitive drilling m/c or Bench drilling m/c
- (3) Upright drilling m/c or pillar drilling m/c
- (4) Radial drilling m/c
- (5) Gang drilling m/c
- (6) Automatic drilling machine
- (7) Deep hole drilling machine
- (8) Multiple spindle drilling m/c

Note In our syllabus, there are only 3 type of drilling machine is to be studied.

- (a) Sensitive or Bench drilling m/c
- (b) upright or pillar drilling m/c
- (c) Radial drilling machine

Q-2 Explain the construction & working of Bench drilling m/c.

Ans

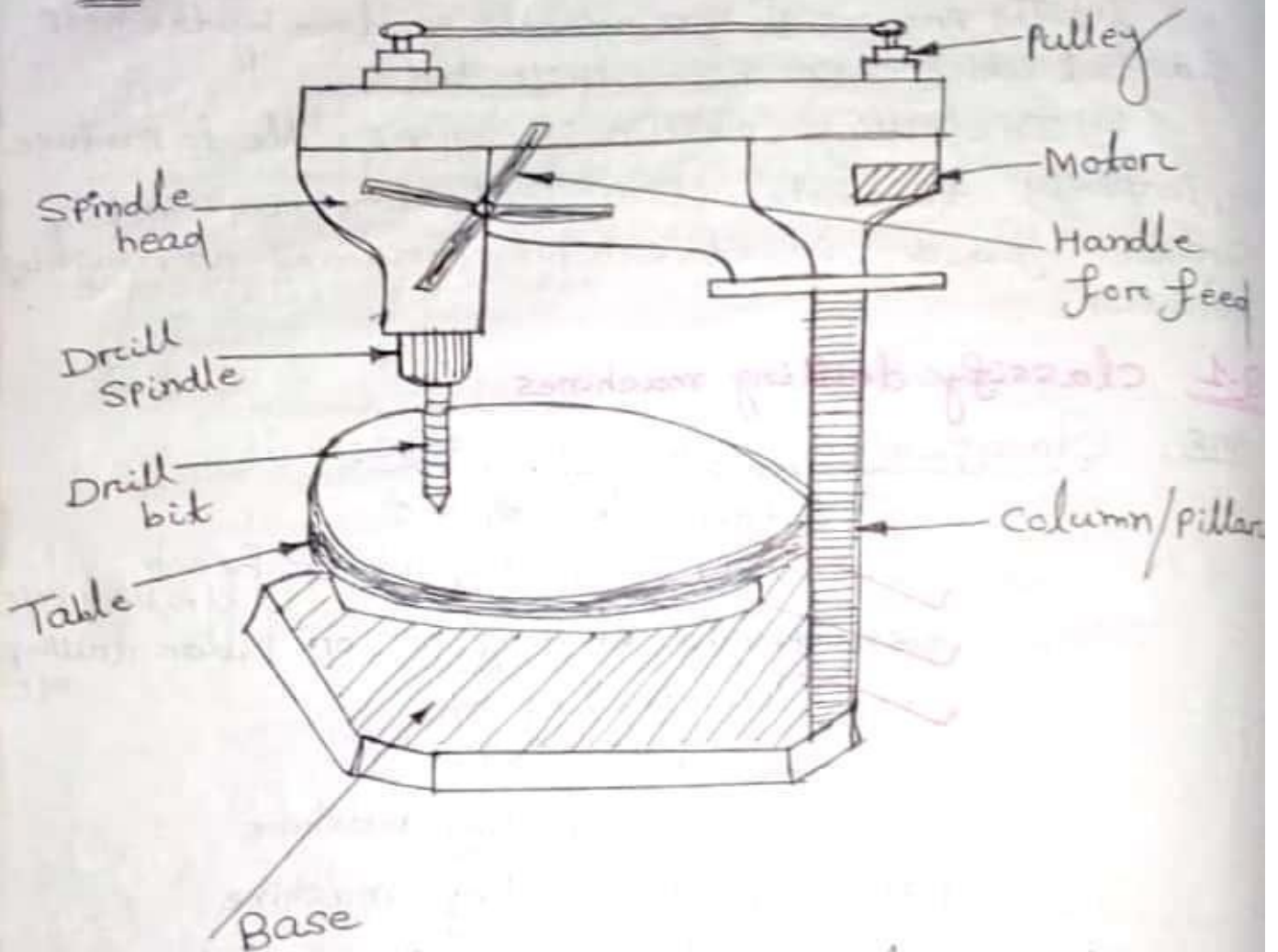

* It is a light, simple bench type machine used for light duty working.

* The machine can hold drills up to 12.5 mm. diameter.

The major components of bench type drilling m/c are

- (1) Base
- (2) Column
- (3) Table
- (4) Drill Spindle
- (5) Drill bit.

Construction Parts

Base:- The base provided support and rigidity to the entire structure of the machine. It is made of cast iron & having a fixed table over it.

Column:-

- (i) The column or pillar is a supporting structure for the table, spindle head and other part of the machine.
- (ii) The column carries a swivelling table.
- (iii) At the top of the column is provided with a motor which act as a drive mechanism for the system.

Table:-

- (i) The table of the drilling m/c supports the workpiece and other clamping devices like drill jigs.
- (ii) By loosening the table clamping handle the table can be adjusted up & down on the column with respect to the drill.

Drill Spindle:-

- (i) The various mechanism of the spindle head powered by the help of motor through belt & pulleys.
- (ii) The top of the column is provided with V-belt running over two pulleys.
- (iii) one of these pulleys mounted over the motor shaft & other is mounted on the spindle head.
- (iv) No gears are used in this drive arrangement.
- (v) Vertical movement of the spindle is given through the feed handle. by rack & pinion arrangement.

Drill bit:-

- (i) Various types of drill bit can be used for drilling purpose according to the requirement.
- (ii) Generally Twist drill are used for drilling operation. It made from HSS & High carbon Steel.

Working Principle

(i) When the switch is on of motor, the motor shaft starts revolving.

(ii) Then the power is transmitted through the V-belt which is mounted on the pulley to the other pulley which is mounted on the spindle head.

(iii) Thus the spindle starts rotating & the drill tool also rotates. by the help of the handle we can give feed.

(iv) The handle is mounted on the ^{Pinion} shaft which is connected to a rack which moves longitudinally.

(v) Different spindle speeds can be obtained by shifting the V-belt to the different pairs of driving & driven pulleys.

(vi) While the motor rotates on the same speed.

(vii) There is no arrangement of automatic feed in this machine.

Q-3 With a neat sketch explain the function of pillar drilling machine.

Ans

(i) The pillar drilling m/c is used for heavy work and has back gearing arrangement as lathe.

(ii) It is coming under up-right drilling machine.

(iii) It especially differs from a sensitive drilling machine in its weight, rigidity, power feed and wide range of spindle speed.

(iv) It can give speed ranging from 75 to 3500 r.p.m. So, obtain this speed range here

PAGE-5
gear box is used instead of belt arrangement.

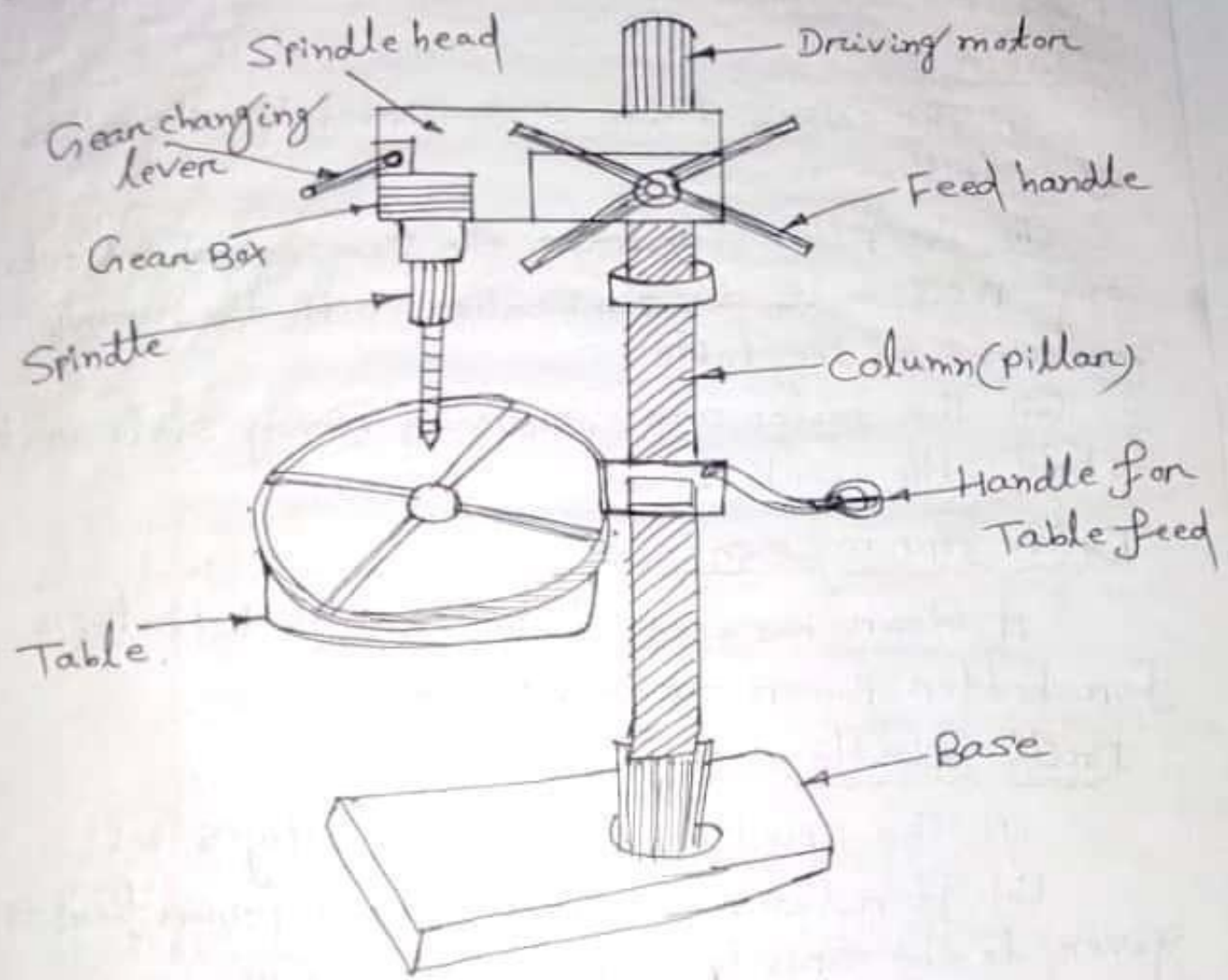

It consist of following parts.

- (1) Base
- (2) Pillar
- (3) Table
- (4) Spindle
- (5) Drill bit
- (6) Drive Arrangement.

Base:- The base of pillar drilling machine is made of heavy casting supports the pillar & spindle head.

Pillar/column:- The pillar is a hollow pipe of casting made of cast iron. It rest from the base & supports the spindle head & table. Here rack & pinion gear present. So, that the table

Can be raised or lowered depending upon the work piece requirement.

Table:-

- (i) The work table is supported by the pillar of a drilling machine.
- (ii) The pillar facilitates the swinging of table to any position & in combination with the rotary movement of the table.
- (iii) The tables are generally having slots on it to hold the work piece.

Drive Arrangement:-

A Gear box is used instead of belt drive for better power transmission.

Drill Spindle:-

- (i) The spindle is made of alloy steel.
- (ii) It rotates the drill & here power feed is given to the spindle for heavier work.
- (iii) It has driven mechanism for changing speeds & feeds and thus a large no. of drill spindles are available to drill different kinds of job.

Q-4 With block diagram explain the construction & working of a radial drilling machine.

Ans The radial drilling machine is used for too large and heavy drill hole.

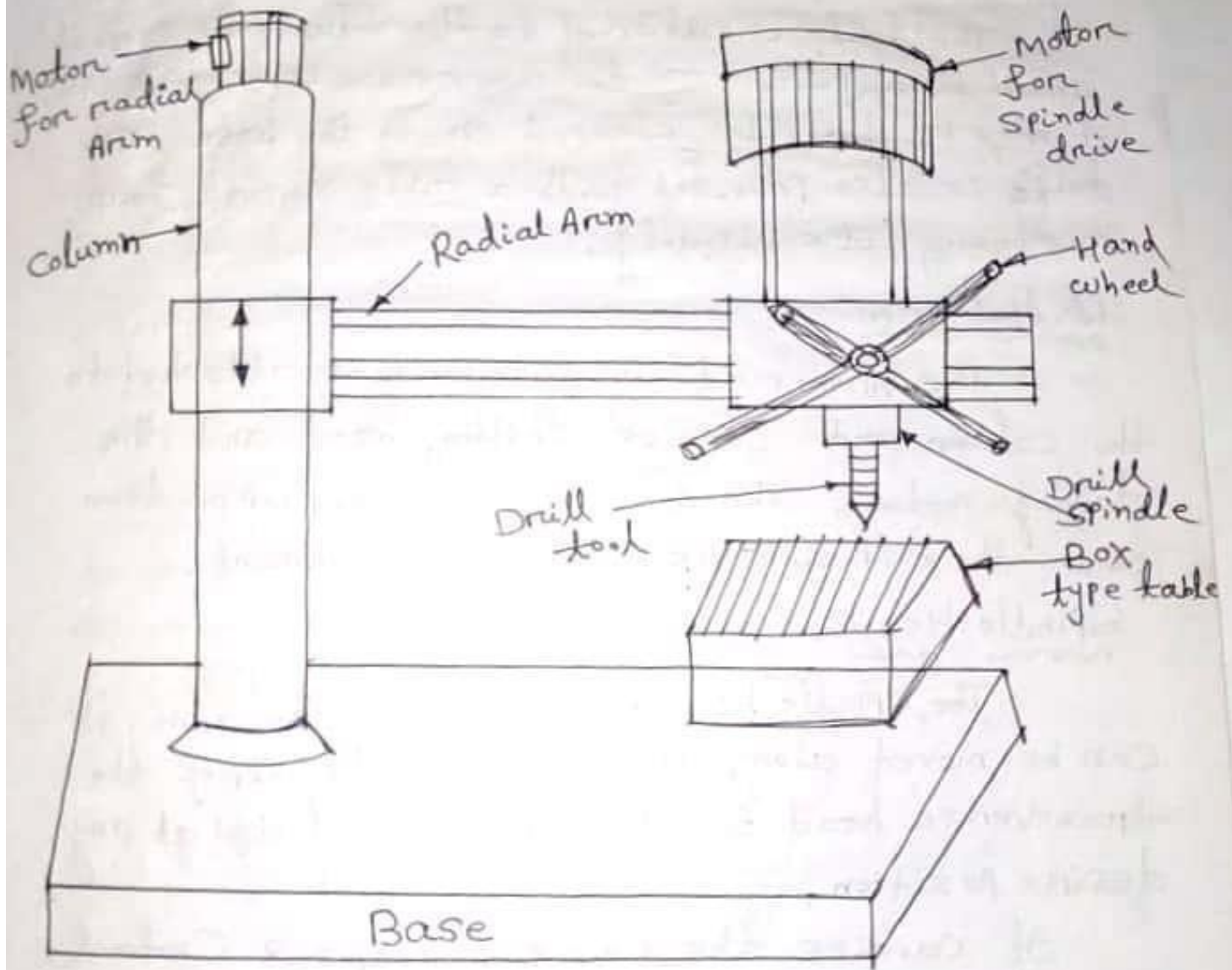

Base:-

- (i) The base is made box type of cast iron.
- (ii) The base carries the column & it may be bolted on bench with the base.
- (iii) The base must be strong enough to give sufficient rigidity & support to the whole structure & other parts.

Column:-

The column is cylindrical & used to support the radial arm. It is made highly rigid and perfectly round in cross-section.

Table:-

The table is attached to the column to support small work piece. If the work piece is very large, it may be directly clamped on to the base. The table is also provided with a table support for increasing its rigidity.

Radial Arm:-

The Arm radially outward is attached to the column and carries drilling head and the driving motor. The Arm can be moved up or down with the help of rack & pinion arrangement.

Spindle Head:-

The Spindle Head is mounted on the arm. It can be moved along the arm with the help of the transverse head wheel and can be locked at any desired position.

It carries the change gears & Control for spindle speed & feed.

Working operation

(i) A separate motor is provided for elevating/ lowering the radial arm and can also be swung round the column to any desired angle.

(ii) Clamping levers are provided for locking the arm at desired height. The spindle head is mounted on the arm which can slide horizontal

on the radial arm.

(iii) These adjustment of the arm & drilling head permit the operator to locate the drill quickly any point of the work.

(iv) Powerful drives are geared directly into the head of the machine and a wide range of power feed are available.

Q-5 Write the basic principle of Boring.

Ans It is the process of enlarging a hole that has already been drilled.

* Boring is used to achieve greater accuracy of the diameter of a hole.

Example This process is to used in large & heavy parts such as engine frames, steam engine cylinder etc.

Q-6 Difference between Boring and drilling.

Ans Boring:-

(i) It is the process of enlarging a hole that is already in the material. This hole made by drilling.

(ii) Boring concerns the internal diameter and the surface of a hole rather than the depth of the hole.

(iii) Boring is done using a boring bar; which is a heavy metal bar with the tool fixed at the end.

Drilling

(i) Drilling is the cutting process of a material using a specially designed rotating cutting tool called a drill bit.

(ii) The holes are produced by the drilling are always cylindrical in drilling process is simple.

(iii) The drill bit is rotated by a drill and pressed against the material, where the tip of the drill bits cuts away the layers of material. By continually pressing against the material, a hole of a desired length can be created.

BROACHING

Q-1 Define Broaching.

Ans It is a method of removing metal by pushing or pulling a cutting tool called a broach which cuts in fixed path.

- * The tool may be pulled or pushed through the surfaces to be finished.

- * Surface finished by broaching may be flat or contoured and may be either internal or external.

- * A broach is a multiple edges cutting tool that has successively higher cutting edges along the length of the tool.

Q-2 Write down types of Broaching.

Ans Types of Broaching

It may be classified in various ways according to :-

1. Type of operation → Internal & external
2. Method of operation → Push & Pull
3. Type of Construction → Solid, overlapping tooth, rotor cut, inserted tooth.

According to our Syllabus Push & Pull broaching Study.

Q-3 Explain about Pull broaching Tool.

Ans Pull Broaching Tool

(i) In Pull broach; the tool is entirely in tension & long slender broaches are possible, having a large no. of teeth.

(ii) In pull broaching methods; the work is held stationary and the broach is pulled through the work. Broaches are held in a special head. Pull broaching is used mostly for internal broaching but it can do some surface broaching.

(iii) Ordinary cut broaches for machining previously drilled or bored holes consist of different elements, which are discussed below.

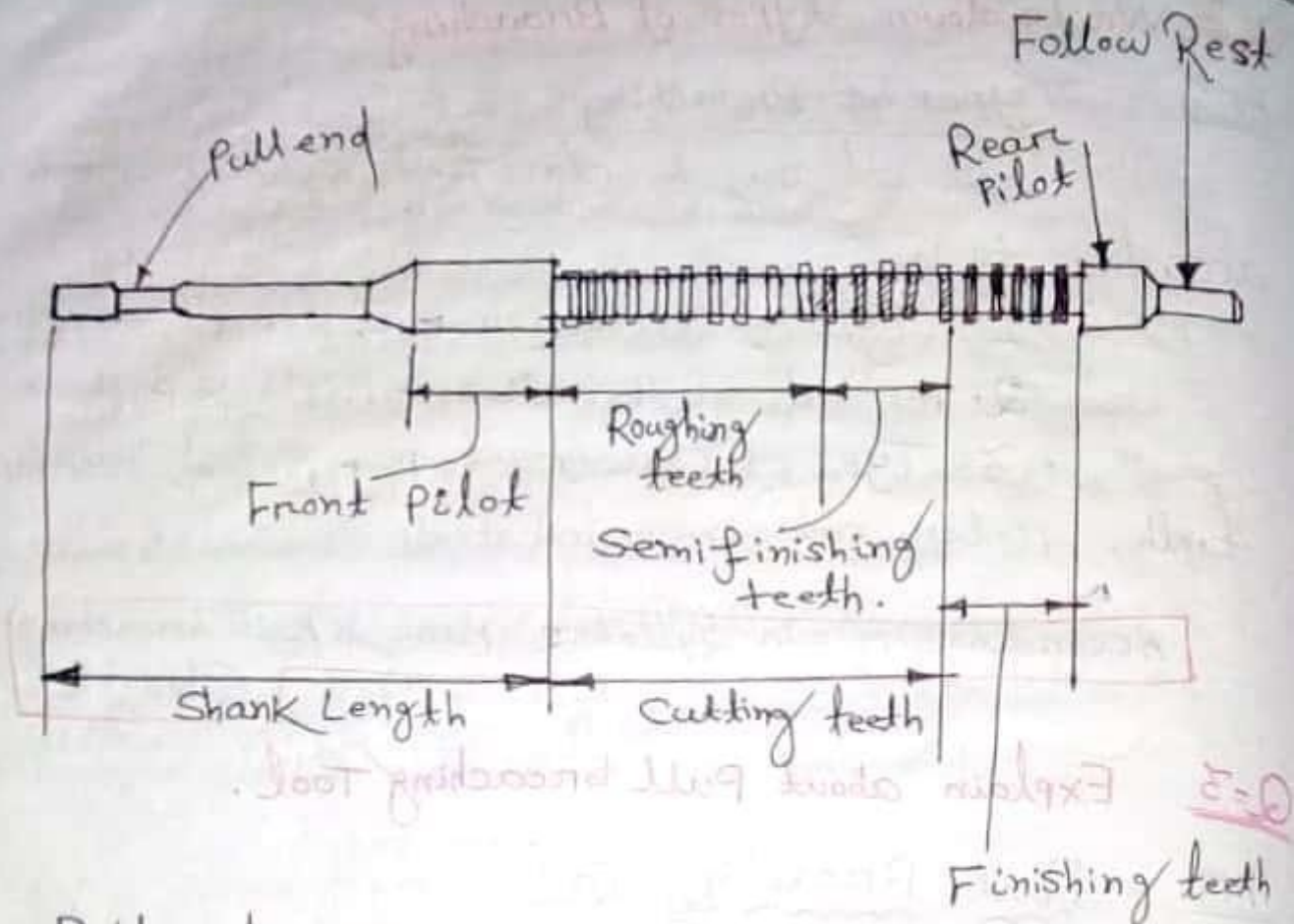

Pull end:-

This is designed to permit engagement of the broach with the broaching machine through the use of a puller ~~head~~ head.

Front pilot

This centres the broach in the hole before the teeth begins to cut.

Roughing & Semi-finished teeth

They Remove most of the stock in the hole.

Finishing Teeth:-

They are for sizing the hole and must have the shape required the finished hole.

Rear Pilot & Follow Rest
They support the broach after the last tooth leaves the hole.

* Push Broaching:-

(i) A push broach is one that is designed to be pushed through the workpiece by special press or push broaching machining. Because of the tendency to bend under compressive loads, the push broach must be short which means, less material can be removed for each pass of the tool.

(ii) In this broaching, the work is held stationary and the broach is pushed through the work.

(iii) Hand & hydraulic arbore presses are popular for push broaching. This method is used mostly for sizing holes and cutting keyways.

Broaching Application

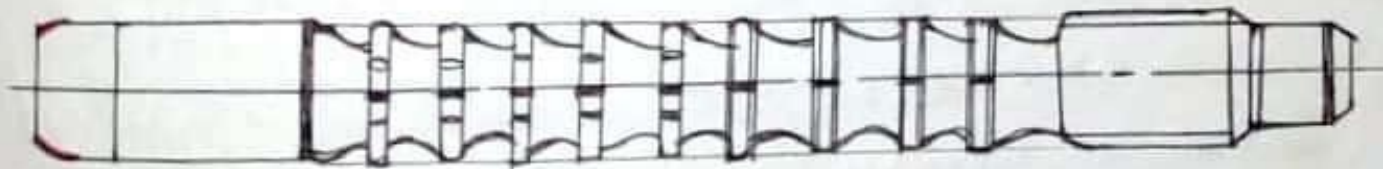

(Figure of Push Broach)

Q-4 What are the advantages of Broaching?

Ans Advantages

- (1) Rate of production is very high. With properly applied broaches, fixtures and machined, more pieces can be turned out per hour by broaching than by any other means.
- (2) Little skill is required to perform a broaching operation.
- (3) High Accuracy and a high class of surface finish is possible.
- (4) Both roughing and finishing cuts are completed in one pass of the tool.
- (5) The process can be used for either internal or external surface finishing.
- (6) Any form that can be reproduced on a broaching can be machined.

Broaching Application

Broaches are used for high production and for finishing high surfaces.



Q-1 Define Surface Finishing.

Ans Super Finishing is the proper function and service life of a machine part depending upon the quality of its surface that is its surface finish.

⇒ Various basic operations like turning, boring, drilling, milling, Shaping etc. are used to produce various parts.

⇒ These parts are accurate in size but they don't carry a very high degree of surface finish for which the service life of the parts decreases.

⇒ So, to obtain highly finish surface various operations are performed as:- Lapping, Honing, Super Finish, Grinding operation etc.

Q-2 Define Superfinishing.

Ans (i) It is a process generally used for achieving high degree surface finish on the components. Removing the scratches or various marks from the work piece.

(ii) It is a not primarily dimension changing process but mainly used for high quality surface finish on the work piece.

(iii) In this process very less amount of metal is removed which ranges from 0.0025 mm to 0.005 mm.

Q-3 Explain Principle of Superfinishing.

Ans

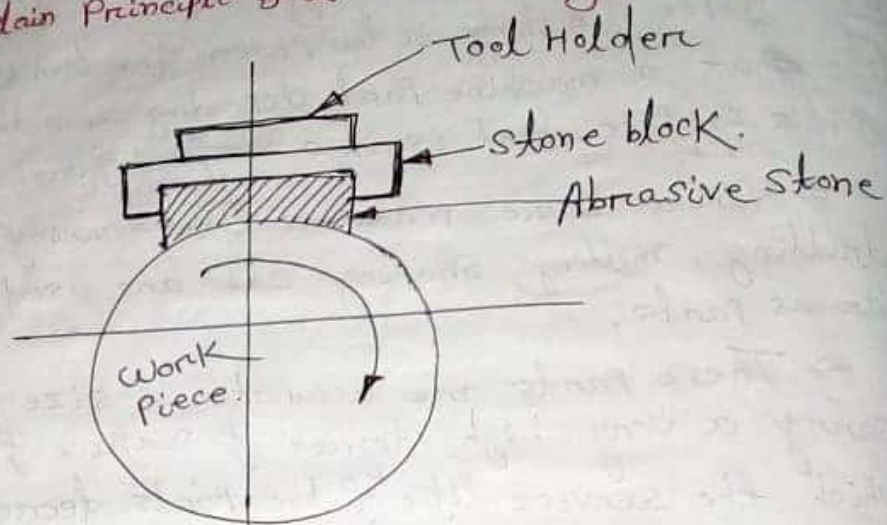

- (i) The principle of Superfinishing is shown in fig. Here the face of abrasive stone is given the shape of the work piece to be super finished.
- (ii) The Abrasive stone block is held in a suitable tool holder & the whole arrangement is placed on the work surface.
- (iii) The work piece is rotated at very slow speed. As the work rotated, the abrasive stone block reciprocates forward & backward at a rapid rate with rubbing of the stone. As a result super finishing surface is obtained.

Q-4 Description about Lapping.

Ans

(i) Lapping is a process employed for improving the surface finish by reducing roughness, waviness and other irregularities on the surface.

(ii) It should be used only where geometrical accuracy is vital with surface finish.

(iii) The material to be selected for making lapping tools are soft cast iron, copper, brass, lead etc.

(iv) Sometimes abrasive particles are also used. These particles are natural and artificial abrasive particles.

(v) Aluminium oxide (Al_2O_3), Silicon Carbide & diamonds are used for lapping materials.

1. Answer All the Questions.

(2x10)

- (a) State the composition of HSS Tool.
- (b) Define depth of cut.
- (c) List the operations carried out in a Lathe.
- (d) What are the types of grinders?
- (e) Define drilling & boring.
- (f) What is super finishing?
- (g) What is the function of Ram?
- (h) Define Abrasive.
- (i) Define grinding.
- (j) What is broaching?

2. Answer Any Six Questions.

(5x6)

- (a) What are the characteristics of tool material?
- (b) Differentiate between Capstan & Turret Lathe.
- (c) Explain working of slotter.
- (d) Describe the properties of coolant & lubricant.
- (e) Explain the specification of grinding wheel.
- (f) With neat block diagram show different components of shaper m/c.
- (g) Explain cutting action of a Reamer.

3. Draw three views of a single point cutting tool & explain the cutting Angles. (10)

4. Explain the working of an Universal dividing head. (10)

5. Explain the Quick Return mechanism of a shaper machine. (10)

6. Describe the composition, properties & use of various cutting tool material. (10)

7. With neat sketch explain the clamping device of a Planner. (10)

ANSWER ANY FIVE QUESTION INCLUDING Q. NO 1 & 2.

1. ANSWER ALL THE QUESTIONS.

- (2x10)
- Define Abrasive.
 - What is the function of ram in sloter?
 - Name the different type of Milling Machine.
 - What are the composition of Carbon steel?
 - Write four main parts of Lathe.
 - Define the multiple tool holder.
 - Why coolants are used?
 - Write four clamping device of a planer m/c.
 - Differentiate between orthogonal & oblique cutting.
 - Define Indexing.

2. ANSWER ANY SIX QUESTION.

- (5x6)
- Explain the working of Radial drilling machine.
 - Explain the method of Taper-Turning operation.
 - Difference between upmilling & Down milling.
 - Explain cutting Action of a hacksaw blade.
 - Explain the Automatic table Feed mechanism of a shaper m/c.
 - Explain the working of Centreless grinder.
 - Draw the diagram of an Universal milling machine & show it's all part.
3. Show & Explain different parts of Capstan Lathe. (10)
4. Explain single point cutting tool Nomenclature. (10)
5. Explain the Quick Return mechanism of a shaper. (10)
6. Explain the manufacturing process of grinding wheel. (10)
7. How we make a hexagonal Nut & bolt? Explain in detail. (10)