

A LABORATORY MANUAL
ON
HYDRAULIC MACHINES & INDUSTRIAL FLUID POWER LAB(Pt.2)
5th SEMESTER MECHANICAL ENGG.

DEPARTMENT OF MECHANICAL ENGINEERING
GOVERNMENT POLYTECHNIC NUAPADA



State Council for Technical Education and Training,
Odisha
Near Raj Bhawan, Unit-8 Bhubaneswar-751012 Odisha

Programme outcomes (POs) and programme specific outcomes (PSOs) to be achieved through the practical of this course: -

1. **Basic and Discipline specific knowledge:** Apply knowledge of basic mathematics, science and engineering fundamentals and engineering specialization to solve the engineering problems.
2. **Problem analysis:** Identify and analyze well-defined engineering problems using codified standard methods.
3. **Design/development of solutions:** Design solutions for well-defined technical problems and assist with the design of systems components or processes to meet specified needs.
4. **Engineering Tools, Experimentation and Testing:** Apply modern engineering tools and appropriate technique to conduct standard tests and measurements.
5. **Engineering practices for society, sustainability and environment:** Apply appropriate technology in context of society, sustainability, environment and ethical practices.
6. **Project Management:** Use engineering management principles individually, as a team member or a leader to manage projects and effectively communicate about well-defined engineering activities.
7. **Life-long learning:** Ability to analyze individual needs and engage in updating in the context of technological changes.

PSOs:

PSO1: Empowered with the knowledge to Design, fabrication, test, operation, or documentation of basic mechanical systems or processes.

PSO2: Developed with skills and gain awareness of technical issues in the field of mechanical engineering in the modern era and provide good service to customer.

SYLLABUS

Pr2.HYDRAULIC MACHINES & INDUSTRIAL FLUID POWER LAB Name of the Course: Diploma in Mechanical Engg.			
Course code:	Semester		5th
Total Period:	60	Examination	3 hrs.
Theory periods:	4 P/W	Sessional:	25
Maximum marks:	100	End Semester Examination:	50

- 1.0 Performance test on impulse turbine and to find out the efficiency
- 2.0 Performance test on Kaplan turbine and to find out the efficiency
- 3.0 Performance test on Francis turbine and to find out the efficiency
- 4.0 Performance test on centrifugal pump and to find out the characteristic curves
- 5.0 Direct operation of single & double acting pneumatic cylinder.
- 6.0 Operating double acting pneumatic cylinder with quick exhaust valve
- 7.0 Speed control double acting pneumatic cylinder using metering in and metering out circuits.
- 8.0 Direct operation of single & double acting hydraulic cylinder
- 9.0 Direct operation of hydraulic motor
- 10.0 Speed control double acting hydraulic cylinder using metering in & metering out circuits

Practical- Course Out come Matrix

Course Out comes:

CO1: Conducting performance test on impulse and reaction turbine

CO2: Conducting performance test on centrifugal pump

CO3: Designing & operating pneumatic circuits

CO4: Designing & operating industrial fluid power circuits

Sl. no	Practical Out come	CO1	CO2	CO3	CO4
1	Performance test on impulse turbine and to find out the efficiency	✓	-	-	-
2	Performance test on Kaplan turbine and to find out the efficiency	✓	-	-	-
3	Performance test on Francis turbine and to find out the efficiency	✓	-	-	-
4	Performance test on centrifugal pump and to find out the characteristic curves	-	✓	-	-
5	Direct operation of single & double acting pneumatic cylinder	-	-	✓	-
6	Operating double acting pneumatic cylinder with quick exhaust valve	-	-	✓	-
7	Speed control double acting pneumatic cylinder using metering in and metering out circuits.	-	-	✓	-
8	Direct operation of single & double acting hydraulic cylinder	-	-	-	✓
9	Direct operation of hydraulic motor	-	-	-	✓
10	Speed control double acting hydraulic cylinder using metering in & metering out circuits.	-	-	-	✓

Experment-1

Aim of the experiment-

Performance test on impulse turbine and to find out the efficiency

Apparatus required:-

01	Impulse Turbine testrig	Pelton wheel	01
02	Tachometer	Digital(0-9999)	01
03	Stop Watch	Digital	01
04	Stator	5 HP	

Theory:

Hydraulic machine are defined as the use machines which convert hydraulic energy to mechanical energy or vice versa.

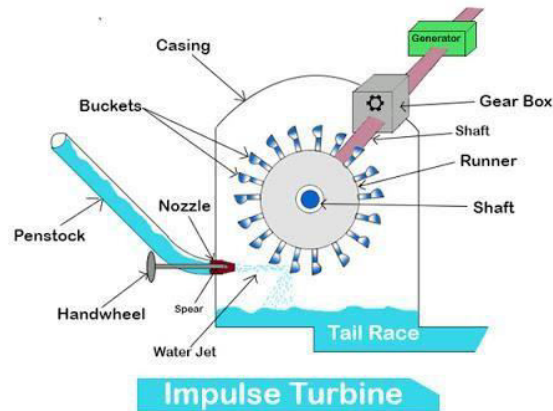

The pelton wheel or pelton turbine is tangential flow impulse turbine .The water strikes the bucket along the tangent of the runner. The Energy available at the inlet of the turbine is only Kinetic energy. The pressure at the inlet and outlet of the turbine is atmospheric. The turbine is used against high head.

The water from the reservoir flows through the penstocks at the outlet to which a nozzle is fitted. The nozzle increases the kinetic energy of water flowing through the penstock. At the outlet of the nozzle the water comes out in the form of a jet and strikes the buckets of the runner.

The main parts of the pelton turbine are:-

- Nozzle and flower gulating arrangement (spear)
- Runner and buckets
- Casing
- Breaking jet

Experiment al procedure:

1. Clean the apparatus & make tank free from dust.
2. Close the drain Valves provided.
3. Ensure that ON/OFF switch given on the panel is at OFF Position
4. Check the tension of the rope (It should be loose)
5. Check the pointer soft he circular spring balance.
6. Check the by-pass valve which should be fully open.
7. Now switch on the main power supply (440vA.C,50Hz)
8. Turn on Starter Pump is started and water is allowed to flow through turbine.
9. Adjust the sphear valve For max .Speed.
10. Adjust the by pass valve for desired inlet water pressure.
11. Load the Fly wheel by lightening the wheel up to1kg.
12. Record the pressure reading and pressure difference of orifice meter , speed reading and spring balance reading .
13. Repeat the experiment for different load.

Technical specification:-

1. Dia of fly wheel (300mm)=0.3meter
2. Diameter of the rope =12mm = 0.012m
3. Weight of rope(W_3) =0.26Kg
4. Diameter of pipe=70mm=0.070m
5. Diameter of orifice=35mm=0.035m
6. Coefficient of discharge(C_d)=0.6
7. Density of water(ρ) =1000 Kg/m³

Observation table:-

SL NO	SHAFT SPEED(N) (rpm)	PRESSURE GAUGE READING(kg/cm ²)	MANOMETER READING		BRAKE WEIGH T(kg) W1	SPRING WEIGH T,kg (W ₂)
			H ₁ in cm	H ₂ in cm		
01						

02						
03						
04						

Calculation:-

$$\text{Overall efficiency}(\eta_o) = \frac{\text{Shaft power}}{\text{Water power}} \times 100$$

$$\text{Shaft power(Output Power)} = \frac{2 \pi NT}{60 \times 1000} \text{ Kw}$$

$$T = W_1 - W_2 + W_3$$

$$\text{Water power(Input Power)} = \frac{\rho g Q H}{1000}$$

$$\text{Discharge(Q)} = \frac{C_d \times a_1 \times a_2 \sqrt{2gh}}{(\sqrt{a_1^2 - a_2^2})} \text{ m}^3/\text{sec} = K\sqrt{h}$$

Where $K = 6.72 \times 10^{-3}$

$$R_e(\text{Equivalent Radius}) = \frac{d_b + 2d_r}{2} \text{ m}$$

h = Pressure difference in or ife meter in m

d_b = Dia. of brake drum (Fly wheel) in m

d_r = Dia .of rope in m

H = Total head of water $\times 10$ in m

Calculation table–

SL NO	Effective Head(H)	Discharge(Q) in m ³ /sec	S.P in Kw	W.P in Kw	Overall efficiency (η_o)
01					
02					
03					
04					

Conclusion:-

Hence we successfully determine the efficiency of Impulse turbine and the value is %.

Practical related questions:

1. What do you mean by impulse turbine?
2. Impulse turbine generally used for which category of head?
3. What is turbine Out put and Input power?
4. What are the different criteria to use impulse turbines?
5. What is coefficient of discharge?

Space for answer

EXPERIMENT-2

Aim of the experiment:-

Performance test on Kaplan turbine and to find out the efficiency

Apparatus required:-

Kaplan turbine test ring.

Specifications:

Supply Pump/motor Capacity:12hp,3ph,440V,50HzAC. Turbine :

150 mm dia.

Propeller with four blades.: Propeller blade angles adjustable from maximum to minimum.

Run-away speed – 2500 rpm (approx.).

Max.flowofwater–2500lpm(approx.) Max.

Head – 10 m. (approx.)

Loading : AC generator.

Electrical Supply:3ph,440V,AC

Theory:-

Hydraulic (or Water) turbines are the machines which use the energy of water (Hydro-Power) and convert it into mechanical energy. Thus the turbine becomes the prime- mover to run the electrical generators to produce the electricity, Viz., Hydro-Electric Power.

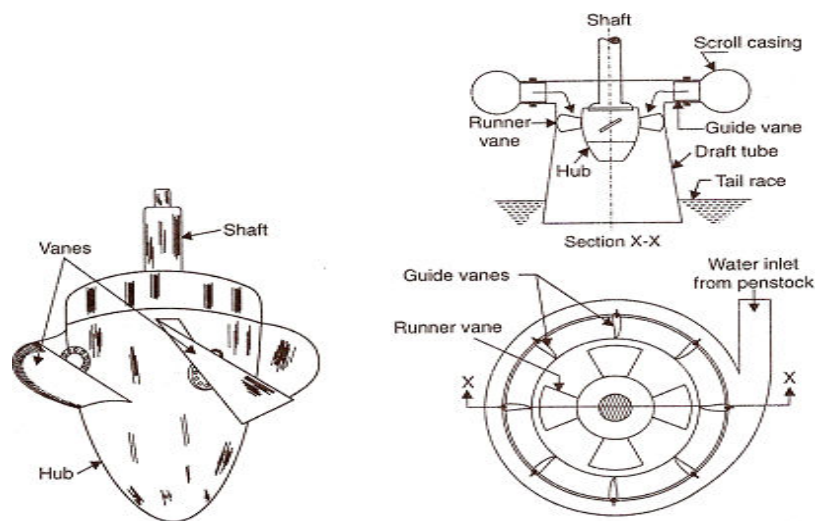

The Kaplan turbine is an inward flow reaction turbine, which means that the working fluid changes pressure as it moves through the turbine and gives up its energy. The design combines radial and axial features.

The inlet is a scroll-shaped tube that wraps around the turbine's wicket gate. Water is directed tangentially, through the wicket gate, and spirals on to a propeller shaped runner, causing it to spin. Between the scroll casing and the runner, the water turns through right angle into the axial direction and passes through the runner and thus rotating the runner shaft. The runner has four blades which can be turned about their own axis so that the angle of inclination may be adjusted while the turbine is in motion. When runner blade angles are varied, high efficiency can be maintained over wide range of operating conditions. In other words even at part loads, when a low discharge is flowing through the runner, a high efficiency can be attained in case of Kaplan turbine, whereas this provision does not exist in Francis & Propeller turbines where, the runner blade angles are fixed and integral with hub.

Experimental procedure:-

1. Connect the supply pump – motor unit to 3 ph, 440V, 30A, electrical supply, with neutral and earth connections and ensure the correct direction of pump-motor unit.
2. Keep the gate closed.
3. Keep the electrical load at maximum, by keeping the all switches at ON position.
4. Press the green button of the supply pump starter & then release.
5. Slowly, open the gate so that the turbine rotor picks up the speed and attains maximum at full opening of the gate.
6. Note down the voltage and current, speed, pressure vacuum on the control panel, head over the notch, and tabulate the results.
7. Close the gate and then switch OFF the supply water pump set.
8. Follow the procedure described below for taking down the reading for reevaluating the performance of the Kaplan turbine.

Specifications:

Supply Pump/ motor Capacity: 12hp, 3ph, 440V, 50Hz AC. Turbine :

150 mm dia.

Propeller with four blades.: Propeller blade angles adjustable from maximum to minimum.

Run-away speed – 2500 rpm (approx.).

Max. flow of water – 2500 lpm (approx.) Max.

Head – 10 m. (approx.)

Loading : AC generator.

Electrical Supply: 3ph, 440V, AC

Observation table:-

SL NO	Head on Turbine)		Turbine speed In RPM	Head over Notch (Flow Rate), "h" in m	Load on Generator		Energy Meter Reading Time for 5 Rev in secs.
	Pressure "P" in Kg / Cm ²	Vacuum "Pv" in mm of Hg			"V" Volts	"I" Amps	
01							
02							
03							
04							

Calculation:-

1. Head on the Turbine 'H' in meters of water = $10 (P + P_v / 760)$ Where P is the pressure gauge reading in Kg / Cm² and P_v is the vacuum gauge reading.

2. Discharge (Flow rate) of water through the Turbine = Flow Rate over the rectangular Notch

$$Q = 2.95 L h^{3/2} \text{ Where, } L = \text{Crest width in m, on substituting for } L = 0.5 \text{ m. } Q =$$

$$1.48 h^{3/2} \text{ m}^3 / \text{sec.}$$

3. Hydraulic Input to the Turbine, $HP_{hyd} = WQH / 75$ Where, W = 1000 kgf/m³ Q

= Flow rate of water in m³ / sec, H = Head on Turbine

4. Break Horse Power of the Turbine, $BHP = \text{Electrical Output} / \text{Efficiency of Generator}$

Where, 0.75 is the Efficiency of Transmission and Generator

$$HP_{elec} = 5 \times 1000 \times 60 \times 60 / E.M \times 736 \times t$$

5. Turbine Efficiency, % = $BHP / HP_{hyd} \times 100$

6. Unit quantities – under unit head,

Unit Speed, $N_u = N/\sqrt{H}$

Unit power, $P_u = P/H^{3/2}$

Unit Discharge, $Q_u = Q/\sqrt{H}$

7. Specific speed, $N_s = N\sqrt{P}/H^{5/4}$ Obtained at maximum efficiency.

8. Percentage Full load = Part load BHP/Max load BHP $\times 100$ at any particular speed.

9. Speed Ratio = $u/\sqrt{2gH}$ Where, $u = \pi DN/60$ = Peripheral Speed and H

= Head on Turbine

Flow Ratio = $V/\sqrt{2gH}$ Where, $V = Q/A$ in which Q is Discharge; A is

rotor annular area = $\pi (D^2 - d^2)/4$

Specific Speed, $N_s = N\sqrt{P}/H^{5/4}$

N – Where, 'N' is the Propeller Speed at Head (H) when developing power 'P'

'H' is in Meter 'N' is in RPM 'P' is in HP

Calculation table:-

SL NO	Turbine Speed in RPM	Net head on Turbine 'H' in m	Discharge (Flow Rate) 'Q' in m ³ /Sec	H Phyd	BHP	$\eta_H\%$
01						
02						
03						
04						

Precautions:

1. Do not start pump stiff the supply voltage is less than 300V (phase to phase voltage).
2. Do not forget to give electrical earth and neutral connections correctly. Otherwise, the RPM indicator gets burnt if connections are wrong.
3. Frequently, at least once in three months, grease all visual moving parts.

4. Initially, fill-in the tank with clean water free from foreign material. Change the water every six months.
5. At least every week, operate the unit for five minutes to prevent any clogging of the moving parts.
6. To start and stop the supply pump ,always keep gate closed.
7. Gradual opening and closing of the gate is recommended port smooth operation.
8. In case of any major faults ,please write to manufacturer ,and do not attempt to repair.
9. Fill the water enough so that the pump does not choke.

CONCLUSION:-

Hence we successfully determine the efficiency of kaplan turbine and the performance is..... %.

Practical related questions:

1. On what principle the Kaplan turbine works?
2. What is the shape and function of draft tube?
3. Why V not chis not used in Kaplan turbine?
4. Define unit quantities and specific speed.
5. What is he nature of flow in Kaplan turbine?

Experment-3

Aim of the experiment:-

Performance test on Francis turbine and to find out the efficiency.

Apparatus required:-

01	Reaction Turbine test ring	Francis Turbine	01
02	Tachometer	Digital type	01
03	Stop Watch	Digital type	01

Theory:-

Reaction turbine means that the water at the inlet of the turbine possesses K. Eas well as pressure energy. The runner is completely enclosed in air tight casing and is full of water. The inward flow reaction turbine having radial discharge at outlet is known as Francis turbine

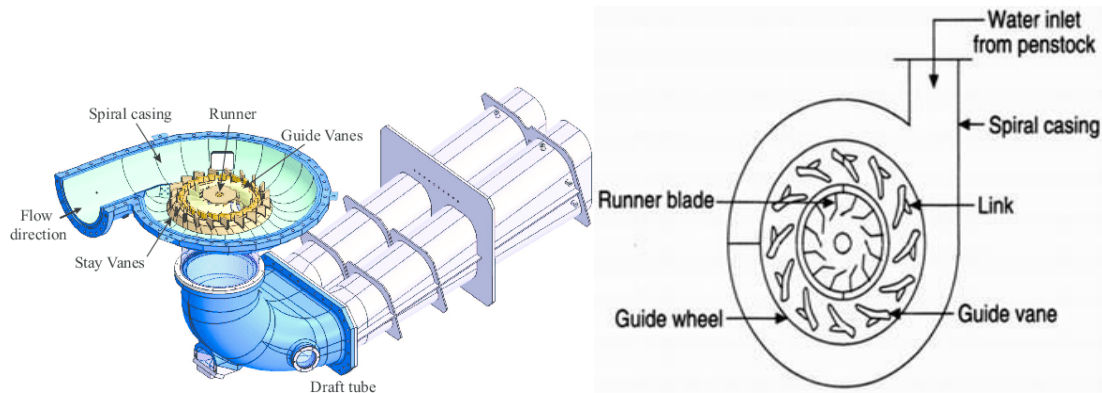

The Francis turbine apparatus consists of spiral casing an outer pedestal bearing and rotor assembly with runner shaft and brake drum all mounted on a suitable frame. A straight conical draft tube is provided for the purpose of regaining the kinetic energy from the exit water and also facilitates easy accessibility of the turbine due to it locating at a higher level than the tail race. A transparent hollow Perspex cylinder is provided in between the draught bend and the casing for the purpose of observation of flow exit of runner. A rope brake arrangement is provided to load the turbine. The output of the turbine can be controlled by adjusting the guide vanes for which a hand wheel and a suitable link mechanism are provided. The net supplied head on the turbine is measured by a pressure gauge.

Experimental procedure:-

- Check whether all the joints are leak proof and water tight
- Prime the pump and start it with closed gate valve.
- Then slowly open the gate valve and open the cock fitted to the pressure gauge and see that the pump develops net head.
- If the pump develops the required head, slowly open the turbine guide vane through suitable link mechanism until the turbine attain the normal speed.
- Run the turbine at normal speed for about 10 minutes measured in stop watch and carefully note the following:-
 1. Operation of the bearings , temperature rise , noise etc.
 2. Vibration of the units.
 3. Steady constant speed and fluctuation if any
 4. If operation of the above parts is normal, add load to the turbine slowly and take readings.
 5. To load the turbine standard dead weight are provided.
 6. Open the water inlet valve and allow some cooling water through the brake drum when turbine runs under load.
 7. The output power of the turbine is calculated from the reading taken on the brake and the speed of the shaft.
 8. Input power supplied to the turbine is calculated from the net supplied head on the turbine and discharge through the turbine.
 9. Efficiency of the turbine being the ratio between the output and input power.

Technical specification:-

Pump size=100×100mm² Motor

= 5Hp

Diameter of the Break drum(D)=200mm

Thickness of rope (t) = 12mm

Effective radius of break Drum (Re)=(D+t)/2=(200+12)/2=106mm=0.106m

Diameter of Inlet pipe (d₁) =7.5cm=0.075m

Cross-sectional area of pipe (a₁)=($\pi/4$)x(d₁)²=($\pi/4$)x(0.075)²=4.41×10⁻³m²

Diameter of throat (d₂)=4.5cm=0.045m

Cross-sectional area of the throat (a₂)=($\pi/4$)x(d₂)²=($\pi/4$)x(0.045)²=1.59×10⁻³m²

Brakeweight=deadweight+(hangerweight+ropeweight)=deadweight+700gm

Observation table:-

SL NO	SHAFT SPEED(N) (rpm)	PRESSURE GAUGE READING (kg/cm ²)	MANOMETER READING			SPRING WEIGHT ,kg(W ₁)	DEAD WEIGHT, kg	BRAKE WEIGHT (kg), W ₂	NET WEIGHT, (W=W ₁ -W ₂), (kg)
			h _{1c} m	h _{2c} m	Δh=12.6 (h ₁ -h ₂)m				
01									
02									
03									
04									

Calculation:-

Net supply head(H)= _____ in mm

$$\text{Discharge (Q)} = \frac{C_d \times a_1 \times a_2 \sqrt{2g\Delta h}}{(\sqrt{a_1^2 - a_2^2})} = \text{_____ m}^3/\text{sec}$$

$$\text{Torque ,T} = W \times Re = 1.3 \times 0.106 = \text{_____ kg-m}$$

$$\text{Brake power, Bp} = 2\pi NT/4500 = \text{_____ Hp}$$

$$\text{Input power, (Ip)} = Q \times H/4500 = \text{_____ Hp}$$

$$\text{Efficiency ,}\eta = (Bp/Ip) \times 100 = \text{_____ \%}$$

Calculation table -

SL NO	Effective Head(H)	Discharge (Q) in m ³ /sec	S.P in Kw	W.P in Kw	Overall efficiency (η _o)
01					
02					
03					
04					

Conclusion:-

Hence we successfully determine the efficiency of Reaction turbine and the efficiency is%.

Practical related questions:

1. On what principle the Francis turbine works?
2. What is the shape and function of draft tube in Francis turbine?
3. What is the purpose of guide vanes?
4. Define unit quantities and specific speed.
5. What type of flow occurs in Francis turbine?

Space for answer

Experiment-4

Aim of the experiment:

Performance test on centrifugal pump and to find out the characteristic curves

Apparatus required:

Centrifugal pump testing ,stop watch.

The present Pump Test Rig is a self – contained unit operated on Closed Circuit (Recirculation) Basis. The Centrifugal Pump, AC Motor, Sump Tank, Collecting Tank, control Panel are mounted on rigid frame work with anti-vibration mounts and arranged with the following provisions:

1. For conducting the experiments at three speeds using AC Motor.
2. To measure overall input power to the AC motor using Energy Meter.
3. For recording the Pressure & vacuum.
4. For recording the speed using Digital RPM Indicator.
5. For changing the pressure (Delivery Head) and Vacuum (Suction Head)by operating the valves.
6. For measuring the discharge by Collecting Tank-Level Gauge provision.
7. For recirculation of water back to the sump tank by over flow provision.

Theory:

In general, a pump may be defined as a mechanical device which, when interposed in a pipe line, converts the mechanical energy supplied to it from some external source into hydraulic energy, thus resulting in the flow of liquid from lower potential to higher potential.

The pumps are of major concern to most Engineers and Technicians. The types of pump vary in principle and design. The selection of the pump for any particular application is to be done by understanding their characteristics. The most commonly used pumps for domestic, agricultural and industrial purposes are; Centrifugal, Piston, Axial Flow (Stage pumps), Air Jet, Diaphragm and Turbine pumps. Most of these pumps fall into the main class, namely, Roto dynamic, Reciprocating (Positive Displacement), Fluid (Air) operated pumps.

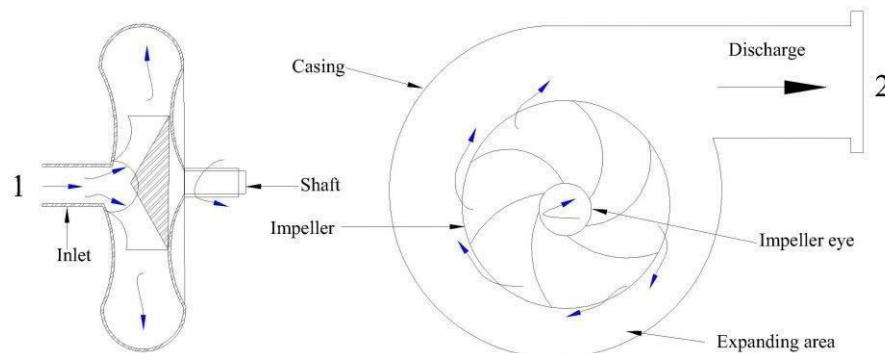

In centrifugal pump the liquid is made to rotate in a closed chamber (Volute Casing), thus resulting in the continuous flow. These pumps compared to Reciprocating Pumps are simple in construction, more suitable for handling viscous, turbid (muddy) liquids. But, their hydraulic head spers tage at low flow rates is limited, and hence not suitable for very high heads compared to Reciprocating Pumps of same capacity. But, still in most cases, this is the only type of pump which is being widely used for agricultural purposes.

Procedure:

All the necessary instrumentations along with its accessories are readily connected .It is just enough to follow the instructions below

1. Fill in the Sump Tank with clean water.
2. Keep the delivery valve closed and suction valve open ,after initially priming the pump.
3. Connect the power cable to 1Ph , 230V ,15 A with earth connection.
4. Confirm the belt is put to the lowest speed position.
5. Switch ON the Mains ,so that the Mains On Indicator glows .Now, switch-ON the starter.
6. Now you will find the water starts flowing to the Measuring Tank.
7. Close the delivery valves lightly ,so that the delivery pressure is read able
8. Operate the Butterfly valve to note down the collecting tank reading against the known time and keep it open when the readings are not taken.
9. Note down the Pressure Gauges ,Vacuum Gauges ,and time for number of revolutions of Energy Meter Disc.
10. Note down the other readings as indicated in the tabular column.
11. Repeat the experiment for different openings of the Delivery Valve and Suction Valve.
12. Change the belt to different speed positions and repeat the experiment.

Precautions:

1. Do not start the pump if the voltage is less than 180V.
2. Frequently (at least once in three months)grease/oil therot acting parts.
3. Initially ,put clean water free from for eign material ,and change once in three months.
4. At least every week, operate the unit for five minute stop revent clogging of the moving parts.
5. Don't exceed 5kg/cm² on pressure gauge reading and never fully close the delivery valve

Specifications:

Electrical Supply : 230V,AC,1Phase ,50Hz with Neutral & Earth Connections. Motor

: AC Motor, 1 HP,1200 RPM

Centrifugal Pump:1.5HP,2000RPM(Max),Kirloska rMake Pressure

Gauge :2 kg / cm²

Vacuum Gauge : 0 – 760 mm of Hg

Energy Meter Constant:1500Rev/KWH

Speed Indicator:0–9999RM(Digital type).

Control Valves :For Suction & Delivery. Measuring tank:0.25m²

Observation table:

SL NO	Speed of pump in RPM(N)	Time taken to collect 10 no. of blinks (t) in sec	Vacuum gauge reading (in mm of Hg)	Pressure gauge reading (Kg/cm ²)	Time to collect 5 c.m height water in tank (In t sec)
01					
02					
03					

Calculation:

1. Basic Data/ Constants:

1HP=746 Watts

1kg/cm²=760mm of Hg (10m of water)

Specific weight of water = 1000 kgf / m³

Energy Meter Constant=1500 Rev./ kWh

Area of Collecting Tank = 0.25 m²

2. Electrical Power as indicated by Energy Meter:

$$HP_{elec} = \frac{10}{1500} \times \frac{1000}{736} \times \frac{3600}{t}$$

Where, "t" is the time taken by the Energy meter for 10 revolutions, in seconds.

3. Discharge Rate "Q" in m³/Sec.

$$Q = \frac{A \times h}{1000 \times t} \text{ in m}^3/\text{sec}$$

Where, "A"=0.25m² is the area of Collecting Tank, "h" = the height of water collected in mm.

"T"=the time taken in seconds for collecting tank.

4. Total Head 'H' in mtr.

H=10(Delivery Pressure + Vacuum Head)

$$= 10[P + (P_v/760)]$$

Where, "P" is the pressure in kg/cm², "P_v" is the vacuum in mm of Hg.

5. Hydraulic Horse Power (Delivered by the Pump):

$$HP_{\text{pump}} = WQH/75$$

Where, "W" = 1000kgf/m³

6. Overall Efficiency:

$$\eta_{\text{overall}} = HP_{\text{pump}} / HP_{\text{elec}} \times 100$$

Head Curve

Feet of head for a given flow rate

Efficiency

Pump efficiency for a given flow rate

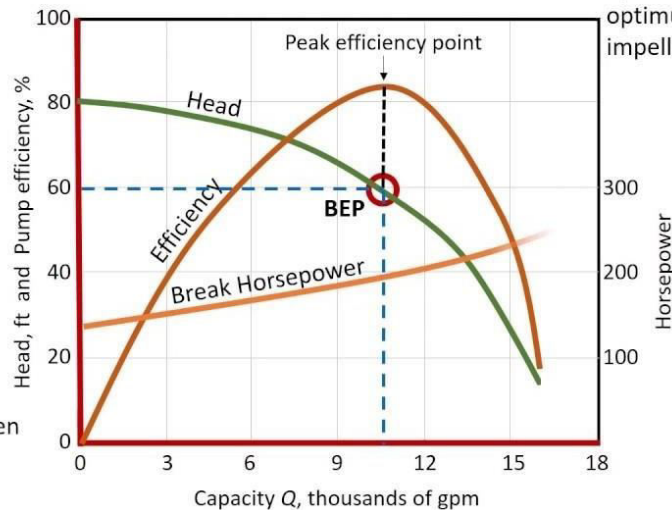

BEP - Best Efficiency Point

The flow at which the pump operates at the highest or optimum efficiency for a given impeller diameter

Tabulation for graph:

SL NO	Head in c.m	Power(P) in Kw	Discharge(Q) in m ³ /sec	Speed(N)
01				
02				
03				

Conclusion:

The overall efficiency for different speeds were calculated and graphs plotted.

1. For belt position -1, the overall efficiency was found out to be _____.
2. For belt position -2, the overall efficiency was found out to be _____.
3. For belt position -3, the overall efficiency was found out to be _____.

Practical related questions:

1. What is meant by a Roto-dynamic machine?
2. What is meant by priming of a pump?
3. What energy is converted in a pump?
4. What type of fluids are pumped by centrifugal pumps?
5. What are the pumping characteristics of a centrifugal pump?

SPACE FOR ANSWER

Experiment No- 05

Aim of the experiment:

Direct operation of single & double acting pneumatic cylinder.

Introduction:

Single Acting Cylinder:

Single Acting Cylinder Pneumatic cylinders are devices for converting the air pressure into linear mechanical force and motion. Based on cylinder action we can classify the cylinders as single acting and double acting. Single acting cylinders have single air inlet line.

Single acting cylinder has one working port. Forward motion of the piston is obtained by supplying compressed air to working port. Return motion of piston is obtained by spring placed on the rod side of the cylinder. Schematic diagram of single acting cylinder is shown in figure. Single acting cylinders are used where force is required to be exerted only in one direction.

Such as clamping, feeding, sorting, locking, ejecting, braking etc.

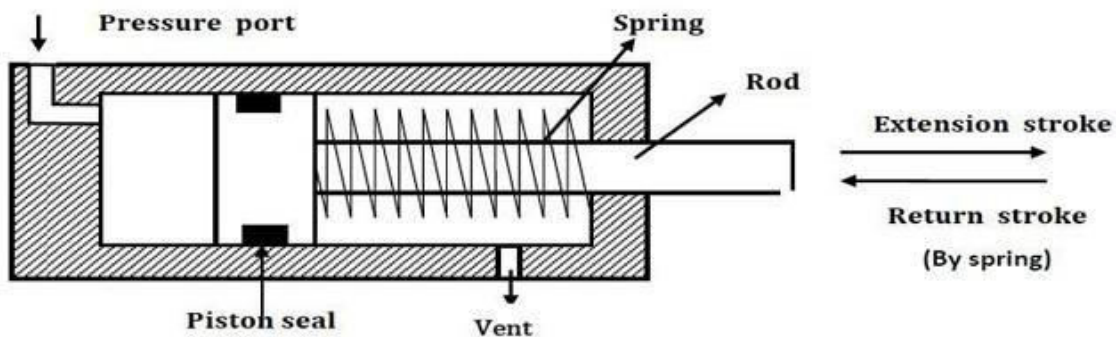

Hand operated 3/2DCV The cross section all views of 3/2DCV (normally closed) based on spool design is shown below. When the valve is not actuated, port 2 and 3 are connected and port 1 is blocked. When the valve is actuated then port 2 and 1 are connected and port 3 is blocked.

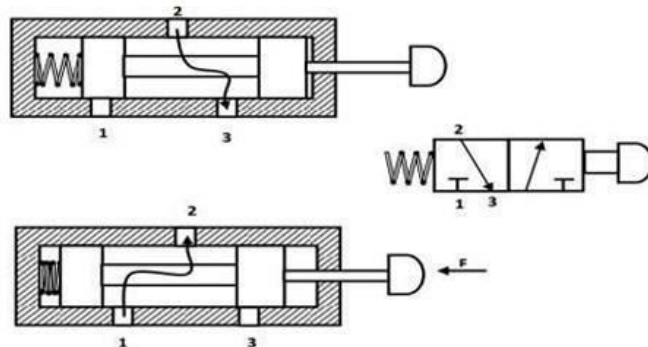

Normally closed 3/2 way direction control valve

Pneumatically actuated 3/2DCV The crosssectional views of pneumatically actuated NC type 3/2 DCV in normal position and actuated positions are shown in the figure.

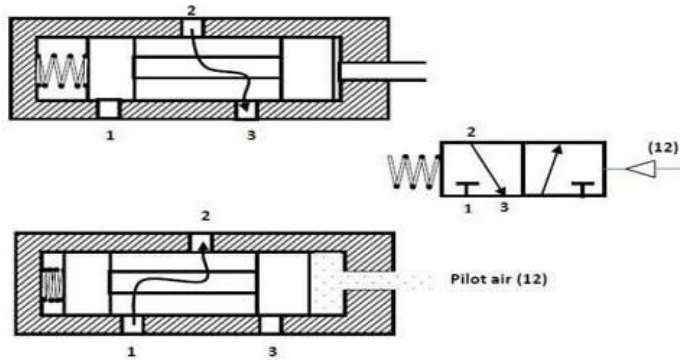

In normal position, the working port (2) is closed to the pressure port (1) and open to the exhaust port (3). When the compressed air is applied through the pilot port (12), the spool is moved against the spring. In the actuated position, the working port (2) is open to the pressure port (1) and closed to the exhaust port (3). Thus, the application of the compressed air to the port 12 causes the pressure port (1) to be connected to the working port (2).

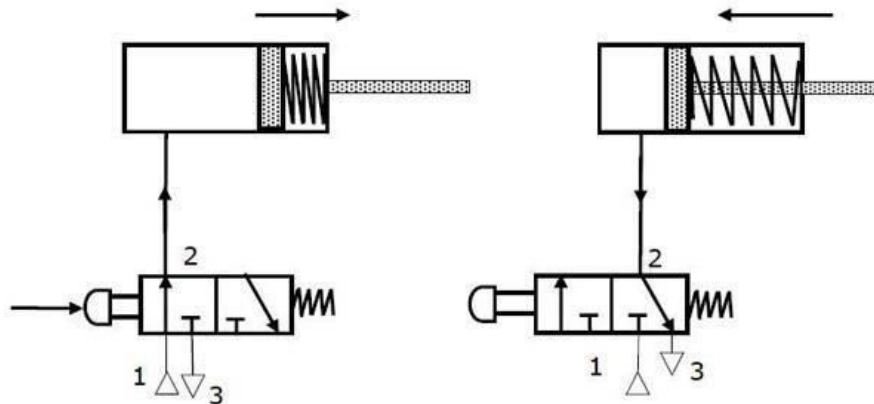

Indirect control of a single acting cylinder This type of circuit is suitable for large single cylinders as well as cylinders operating at high speeds. The final pilot control valve is actuated by normally closed 3/2 push button operated valve.

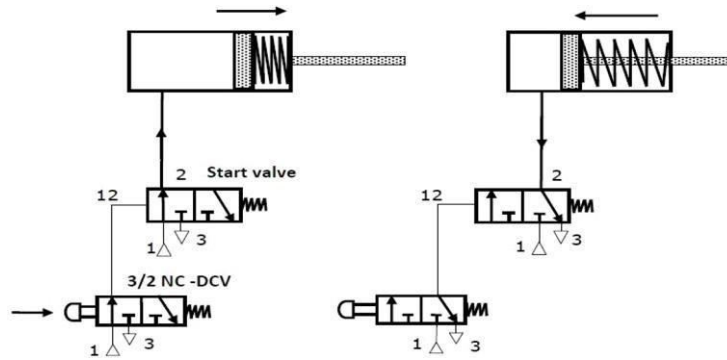

Double-acting cylinders

Double-acting cylinders (DAC) use the force of air to move in both extend and retract strokes. They have two ports to allow air in, one for out stroke and one for in stroke. Stroke length for this design is not limited, however, the piston rod is more vulnerable to buckling and bending. Additional calculations should be performed as well.

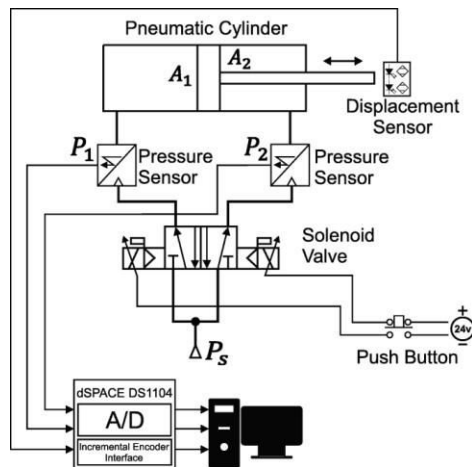

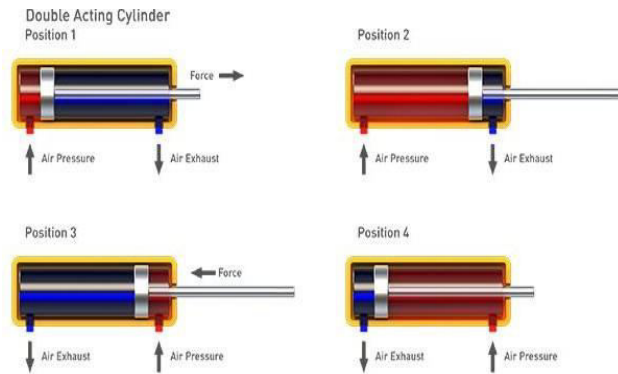

Double-acting cylinders are typically used in all applications where the thrusts and stroke lengths required are in excess of those available from single-acting cylinders. Small double-acting cylinders are also used for applications where positive end-of-stroke positions are required for both strokes.

Double-acting cylinders are the most widely used of all designs of linear actuators. They account for approximately 95% of all cylinders used in pneumatic control circuits.

Procedure:

1. At first the compressed air from the compressor came.
2. Then air will move to Filter regulator (FR)
3. Then it goes through flow valve to direction control valve (DC Valve)
4. Lastly the air will go inside main cylinders.

Conclusion:

With this experiment we came to know that single acting, double acting and different types of valves which are used for pneumatically operated cylinders.

Practical related questions:

1. What is Pneumatics?
2. The basic difference between single acting & double acting Pneumatic cylinders?
3. What are the different functions of Pneumatic cylinders?
4. What is the function of Filter regulator (FR)?

Experiment No- 06

Aim of the experiment:

Operating double acting pneumatic cylinder with quick exhaust valve

Quick exhaust valve:

- This is carried out by incorporating a quick exhaust valve.
- There are 3 essentially ports. supply port is connected to the output of the final central element (Directional control valve). The output port of this valve is directly fitted on the working port of cylinder. The exhaust port is left open to the atmosphere.

Quick Exhaust Valve

- These valves help mainly the DC valves to quickly exhaust
- They are used for quick operation of actuators

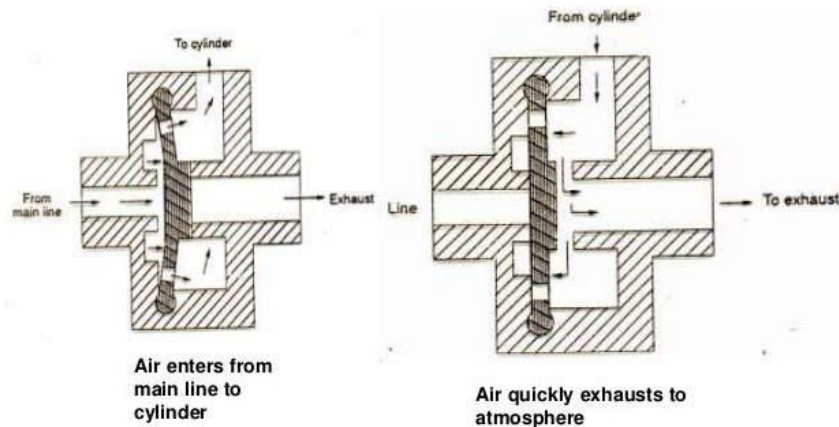
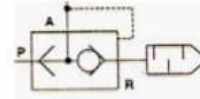

Double acting quick exhaust valve procedure:

The quick exhaust valve is typically in conjunction with 3or4 way directional control valves.

When its inlet port is connected to the supply pressure, it automatically seals its exhaust port and allows pressure to enter its cylinder. Valve is shifted so that it can exhaust the supply to the cylinder. There silent disc moves away from the exhaust port and allows the trapped air in the cylinder to quickly exhaust directly to the atmosphere.

Procedure:

- Start the compressor to suction of air.
- Then the air go through the check valve to enter the pneumatic system & to prevent back flow.
- Then the accumulator stores the air.
- Then the air is pass through air filter regulator device to filtrations of air& a pipe to connected pressure gauge to measure the pressure.
- The air passed through different types of valves like 3/2,5/2 solenoid valve and hand operated valve ,quick exhaust valve.
- Then the pressurized air directly act on the single and double acting cylinder and motion it.

Conclusion:

With this experiment we came to know about the working of the double acting quick exhaust valve.

Practical related questions:

1. How double acting Pneumatics cylinder works?
2. What is the function of quick exhaust valve?
3. How solenoid valve operates?
4. What is $\frac{3}{4}$ directional control valve?

Experiment No- 07

Aim of the experiment:

Speed control double acting pneumatic cylinder using metering in and metering out circuits.

Theory:

A meter in circuit mainly uses flow control valve & check valve meter in circuits work well with fluids .Metering in circuits are used for controlling of extending velocity of a piston & cylinder.

A Meter out flow control circuit is that which restricts the air or liquid as it leaves actuator ports . Meter out circuits work well with both hydraulic & pneumatic actuators.

Working of meter in & meter out circuit:

Fluid Power Circuits Speed Control Circuits:

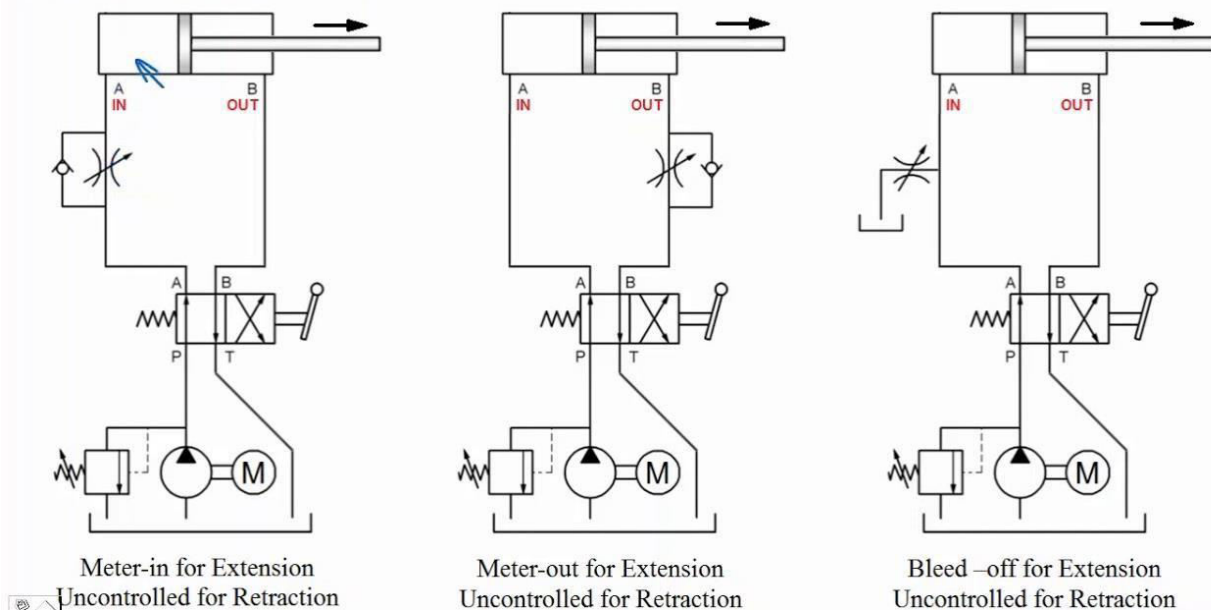

In pneumatic system , cylinder movement maybe jerky because air is compressible. As air flow into a cylinder, as pressure increases slowly unit it generates the break way forge needed to start the lord moving .Because the subsequent force needed to keep the load moving as always less than the break way force , the air in the cylinder actually expand .

The expanding air increases the cylinder speed causing it .to long forward . The piston moves faster than the incoming air can fill the cylinder , pressure drops to less than it takes pressure starts to built again oover come break way force & the process repeats .The larging movement can continue to the end of the stroke.

A metering out circuit is best control to avoid air cylinder lagging. By restricting flow out of the cylinder, the action will be smooth when the load remains constant. When changing from a faster to slower speed, the action will be abrupt. This type of flow control circuits like metering in and metering out circuits control the existing the cylinder.

This type of flow control circuits like metering in and out work for any type of load works best with air operated devices.

Procedure:

1. At first the air flows in to the cylinder.
2. Then the pressure gets increased slowly.
3. Expanding air increases the speed of the cylinder.
4. Incoming air fill the cylinder then the pressure drops.
5. Then pressure began to start to rebuilt over come break way & the process repeated.

Conclusion:

With this experiment, we conclude the study & speed control system of pneumatics cylinder using metering in & metering out circuits.

Practical related questions:

1. How metering in circuits control the speed?
2. What do you mean by metering in & metering out circuits?
3. What is control valve?
4. How speed control of hydraulic cylinder works?

ExperimentNo- 08

Aim of the experiment:

Direct operation of single & double acting hydraulic cylinder

Single acting hydraulic cylinder:

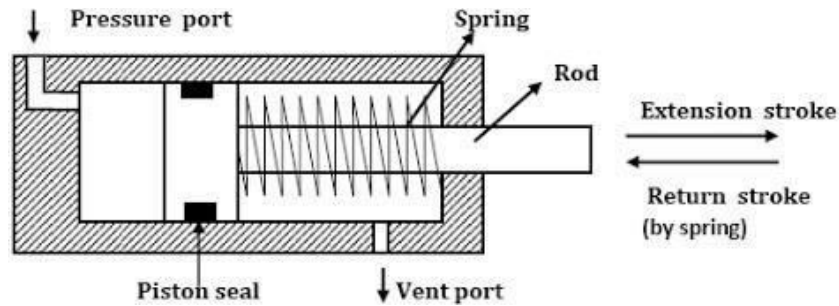

This cylinder only has a head end port & is operated hydraulically in one direction when oil is pumped into a part .It pushes on a plunger thus extend in git .To return or retract a cylinder. Oil must be released to reservoir. A plunger return either because of the of the weight of a load on from some mechanical force such as a spring.

In mobile equipment ,flow to & from single acting cylinder is controlled by are versing directional valve of a single acting type.

Double acting hydraulic cylinder:

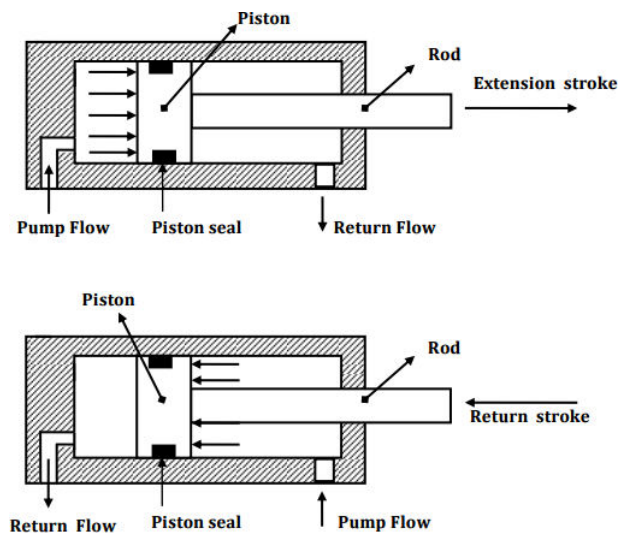

This cylinder must have ports at the head and rod ends. Pumping oil into the head and rod ends. Pumping oil into the head end moves a piston to extend a rod while any oil in the rod end is pushed out and returned to a reservoir. To retract a rod, flow is reversed. Oil from a pump goes into a rod end and a head end port is connected to allow return flow. The flow direction to and from a double acting cylinder can be controlled by a double acting directional valve or by actuating a control of a reversible pump.

Valves :

Valves are used in hydraulic system to control the operation of the actuators. Valves regulate the pressure by creating special pressure condition and by controlling how much oil will flow in portion of a circuit and where it will go.

Types of valves used in hydraulic cylinder-

1. Hydraulic Pressure Control Valve:

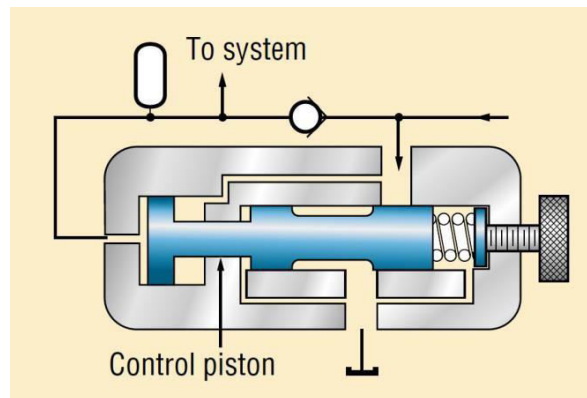

The hydraulic pressure control valve plays a vital role in controlling the leakages and bursting of pipes. Pressure control valves regulate the pressure of the fluid passing through the pipe by releasing the excess pressure. These valves maintain the pressure as entered manually by the operator.

Hydraulic pressure relief valve, sequence valve, counter-balance valve and pressure reducing valve are the different types. The counter-balance valve create dynamic control with in the system and the sequence valve, detects the extreme pressure. The pressure relief valve is one of the important types that set the pressure limit by transferring excess back to the tank.

2. Directional Control Valve:

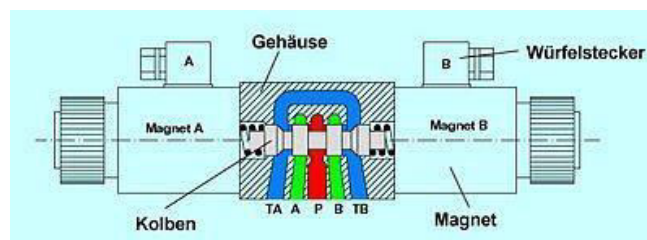

As the name suggests, the directional control valves are used to direct the flow of fluid through the system. These valves can pause and restart the movement of fluids. Also, they can change the direction of fluid flow. Check valve, pre fill valve, spool valves, etc. are the various directional control valves used for ensuring proper flow of fluids within the system. The check valves and pre fill valves are non-return valves. Check valves block bidirectional fluid flow and control the pressure. Whereas, the pre fill valve passes the fluid through the hydraulic cylinder and tank. Spool valves control the fluid flow within the system.

3. Hydraulic Flow Control Valve:

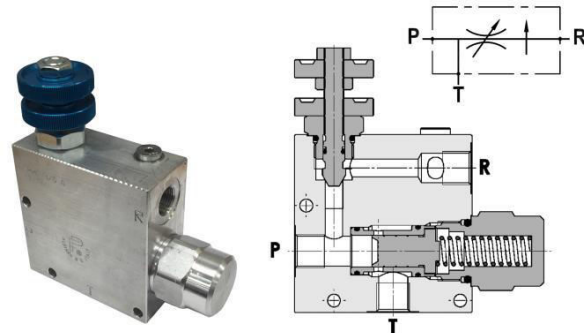

The flow control valves are used for controlling and adjusting the fluid or gas flow through the system. These valves can optimize the hydraulic system performance. Flow control valves will monitor and regulate pressure fluctuations in the system. It prevents the flow towards ill-founded system components.

The throttle valve, speed control valve, manifold set flow valve etc. are the types of flow control valves. Another type of flow control valve is flow divider. This valve takes fluid input from one source and redirects this fluid to two or more sources.

4. Manifold:

A Hydraulic manifold is a component, which regulates fluid flow between pumps & actuators and other components in a hydraulic system.

5. Regulator:

A pressure regulator is a valve which regulates or automatically cuts off the flow of a liquid or gas at a certain pressure, usually for the purpose of preventing damage to piping.

Circuit diagram of single acting hydraulic cylinder:

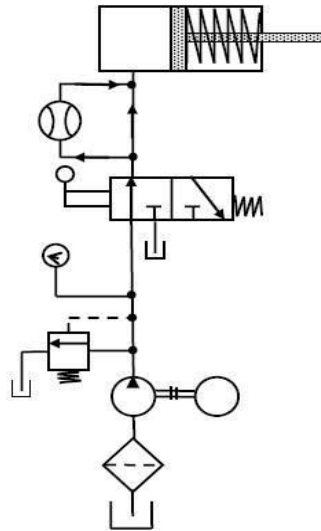

Above Figure shows that the control of a single-acting, spring return cylinder using a three-way two-position manually actuated, spring of f set direction-control valve (DCV). In the spring off set mode, full pump flow goes to the tank through the pressure-relief valve (PRV). The spring in the rod end of the cylinder retracts the piston as the oil from the blank end drains back into the tank. When the valve is manually actuated into its next position, pump flow extends the cylinder.

After full extension, pump flow goes through the relief valve. Deactivation of the DCV allows the cylinder to retract as the DCV shifts into its spring offset mode.

Circuit diagram of double acting hydraulic cylinder:

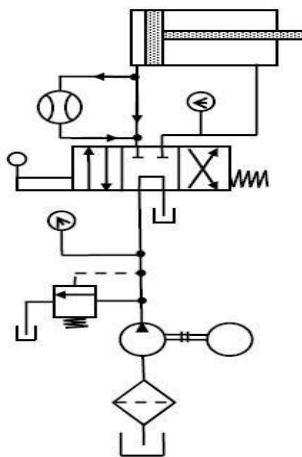

The circuit diagram to control double-acting cylinder is shown in Figure. The control of a double-acting hydraulic cylinder is described as follows:

1. When the 4/3 valve is in its neutral position (tandem design), the cylinder is hydraulically locked and the pump is unloaded back to the tank.

2. When the 4/3 valve is actuated into the flow path, the cylinder is extended against its load as oil flows from port P through port A. Oil in the rod end of the cylinder is free to flow back to the tank through the four-way valve from port B through port T.

3. When the 4/3 valve is actuated into the right-envelope configuration, the cylinder retracts as oil flows from port P through port B. Oil in the blank end is returned to the tank via the flow path from port A to port T.

At the end of the stroke, there is no system demand for oil. Thus, the pump flow goes through the relief valve at its pressure level setting unless the four-way valve is deactivated.

Conclusion:

From this experiment, we came to know about the working & performance of single acting double acting Cylinders with circuit diagram.

Practical related questions:

1. What is Hydraulic system?
2. The basic difference between single acting & double acting Hydraulic cylinders?
3. What are the different functions of Hydraulic cylinders?
4. What is the function of manifold

Experiment No- 09

Aim of the experiment:

To study the direct operation of hydraulic motor

Hydraulic motors:

Hydraulic motor converts fluid pressure in to rotary motion .pressurized fluid from the hydraulic pump turns the motor output shaft vanes of the hydraulic motor.

Hydraulic motor can be used for direct drive application where sufficient torque capacity is available or through gear reductions. Most hydraulic motor must operate under reversible rotation and breaking conditions.

All types of hydraulic motors have common design features :ad riving surface are as subject to pressure differential; a way of timing the porting of pressure fluid to the pressure surface to achieve continuous rotation; and a mechanical connection between the surface area and an output shaft.

The ability of the pressure surfaces to with stand force ,the leakage characteristics of each type of motor, and the efficiency of the method used to link the pressure surface and the out put shaft determine the maximum performance of a motor in terms of pressure ,flow, torque out put, speed, volumetric and mechanical efficiencies, service life, and physical configuration.

Types of hydraulic motors:

1. Gear Hydraulic motor
2. Piston Hydraulic motor
3. Vane Hydraulic motor

Gear Hydraulic motor :

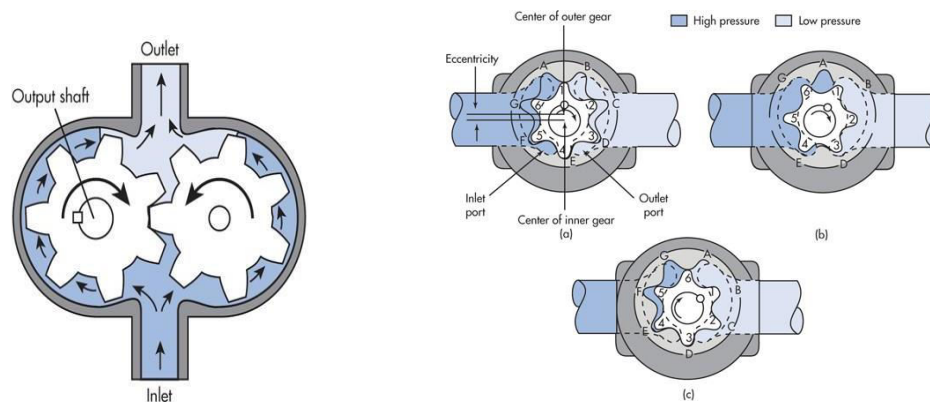

- External gear motors consist of a pair of matched gears enclosed in one housing. Both gears have the same tooth form and are driven by pressure fluid. One gear is connected to an output shaft. The other is an idler. Pressure fluid enters the housing at a point –
- where the gears mesh. It forces the gears to rotate and follows the path of least resistance around the periphery of the housing. The fluid exits at low pressure at the opposite side of the motor. Close tolerances between gears and housing help control fluid leakage and increase volumetric efficiency. Wear plates on the sides of the gears keep the gears from moving axially and help control leakage.

Piston Hydraulic motor:

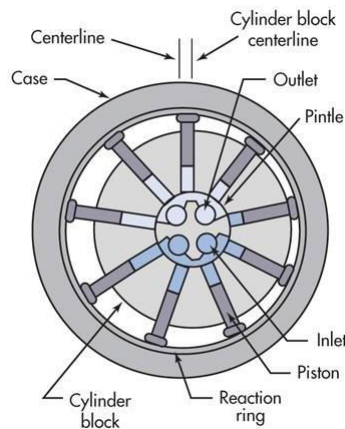

Radial-piston motors have a cylinder barrel attached to a driven shaft. The barrel contains a number of pistons that reciprocate in radial bores. The outer piston ends bear against a thrust ring. Pressure fluid flows through a pintle in the center of the cylinder barrel to drive the pistons outward. The pistons push against the thrust ring and the reaction forces rotate the barrel.

Shifting the slide block laterally to change the piston stroke varies motor displacement. When the centerlines of the cylinder barrel and housing coincide, there is no fluid flow and therefore the cylinder barrel stops. Moving the slide past center reverses the direction of motor rotation.

Vane Hydraulic motor :

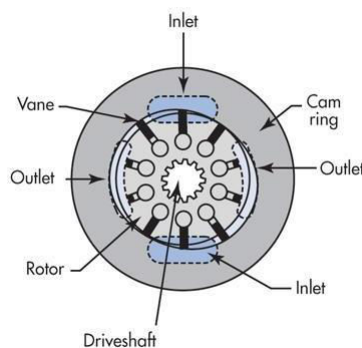

Vane motors have a slotted rotor mounted on a drive shaft that is driven by the rotor Vanes, closely fitted into the rotor slots, move radially to seal against the cam ring .The ring has two major and two minor radial sections joined by transitional sections or ramps. These contours and the pressures introduced to them are balanced diametrically.

Pressure fluid enters and leaves the motor housing through openings in the side plates at the ramps. Pressure fluid entering at the inlet ports moves the rotor counterclockwise. The rotor transports the fluid to the ramp openings at the outlet ports to return to tank. If pressure were introduced at the outlet ports, it would turn the motor clockwise.

Conclusion:

From the above study we learn different types of gear motors with the operations.

Practical related questions:

1. What is hydraulic motor?
2. What are the different types of hydraulic motor?
3. What is Gear Hydraulic motor
4. What is Vane Hydraulic motor
5. What is Piston Hydraulic motor

ExperimentNo- 10

Aim of the experiment:

To study the Speed control double acting hydraulic cylinder using metering in & metering out circuits

Theory:

In the meter in circuit the flow rate goes in to the end of the cylinder while in the meter out circuit the flow rate comes out of the rod end of the cylinder .

Speed control of a hydraulic cylinder is accomplished using a flow control valve .A flow control valve regulates the speed of the cylinder by controlling the flow rate to and of the actuators .

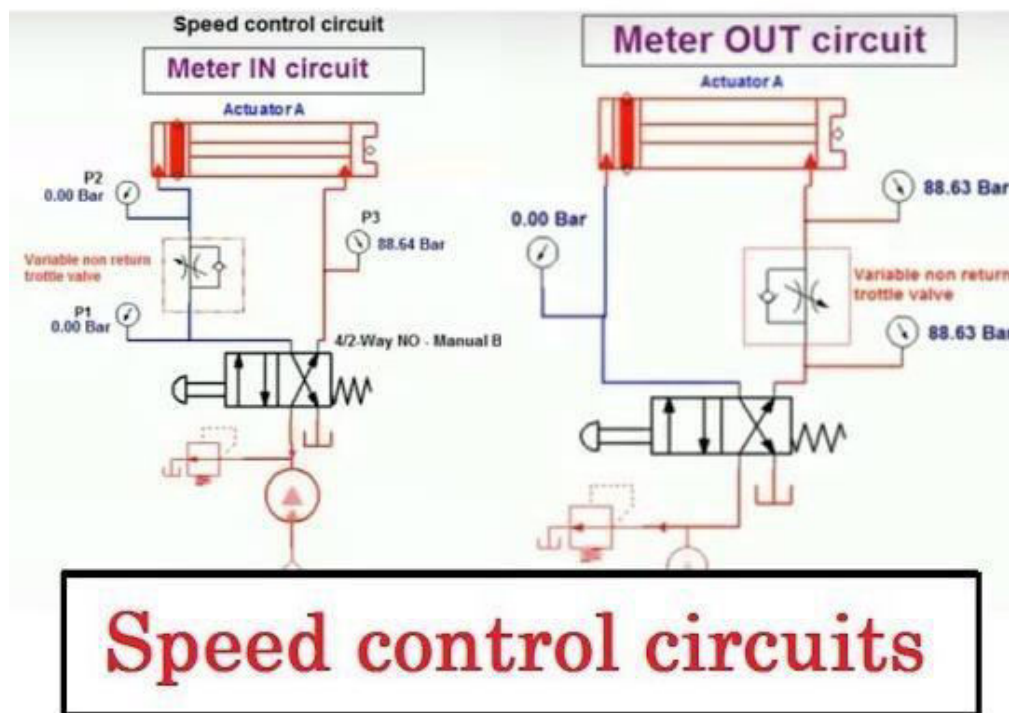

1. Meter in Circuit:

- A meter in circuit mainly uses flow control valve and check valve.
- Meter-in circuits work well with hydraulic fluids.
- Meter in circuits are used for controlling of extending velocity of a piston in cylinder

- Working of ammeter in circuit Meter-In flow control circuit restricts fluid as it enter sanactuator port.

- Meter-in circuit sworks well with hydraulic fluids ,but can give errati caction with air.

2. Meter out Circuit:

- Figure shows a schematic drawing of a meter om flow control circuit that restricts fluid as it leaves an actuator port .Meter-out circuits work well with both hydraulic and pneumatic actuator.

- The direction al control valve shifts to straight arrows and pump flow by passes the upper flow control to go to the cylinder cap end.

- Fluid leaving the cylinder rod end I sheld back before it goes to tank –even with an external load trying to move it.

- The cylinder extend satared uced speed in both hydraulic and pneumatic circuits meets a resistance it can't overcome or it bottoms out.

Conclusion –

From this experiment twelear bout speed controlofdoubleactinghydrauliccylinderwith metering in and metering out.

Practicalrelatedquestions:

1. Howmeteringinormeteringoutcircuitscontrolthespeed?
2. Whatdoyoumeanbymeteringin&meteringoutcircuits?
3. Whatiscontrolvalve?
4. Howspeedcontrolofhydrauliccylinderdone?

